

INSTRUCTION BOOK

A·J·S

350 c.c. SINGLE CYLINDER MODELS 500 c.c.

500 c.c. TWIN CYLINDER MODELS 600 c.c.



Factories :

*BURRAGE GROVE and MAXEY ROAD
PLUMSTEAD, S.E.18*

Telephone : WOOLWICH 1223 (7 lines)

Telegrams : "ICANHOPIT, WOL-LONDON"

Cables : "ICANHOPIT, LONDON" TELEX 22617

Codes : A.B.C. 5th and 6th Edition ; Bentley's ; and Private Codes

Registered Offices :

**PLUMSTEAD ROAD, PLUMSTEAD
LONDON, S.E.18 .. ENGLAND**

— Issued by : —

A.J.S. MOTOR CYCLES : LONDON S.E.18

Proprietors : ASSOCIATED MOTOR CYCLES LTD.

CONTENTS

	Page
Carburetter	46
Controls	9
Data	6
Driving	11
Electrical Equipment	75
Engine	28
Forks and Frame	58
Free Service	93
Guarantee	97
Index	98
Information	87
Lubrication	14
Maintenance	26
Repairs and Service	90
Spare Parts	94
Tools and Special Equipment	95
Transmission	49
Wheels and Brakes	66

ILLUSTRATIONS

	Illustrations	Page
A.C. alternator	39	75
Auto ignition control	18	38
A.V.C. unit	43	81
Battery	44	82
Brake adjustment, front	35	71
Brake adjustment, rear	36	72
Brake pedal adjustment	37	73
Brake shoe adjustment	34A	70
Carburetter	21	47
Clutch	25	54
Clutch shock absorber	26	54
Contact breaker	41	78
Controls	1	10
Crankshaft	8	21
Cylinder head—Singles	16	34
Engine non-return oil valve	9	22
Engine lubrication	6	19
Flywheels—Singles	15	33
Footchange mechanism	23	50
Fork, exploded view	29	61
Fork, damper details	28	59
Front chain adjustment	27	56
Front chaincase	24	51
Gearbox	22	49
Gear lever positions	2	12
Head lamp	46	84
Hub bearing details, front	33	67
Hub bearing details, rear	34	69
Hubs	32	67
Ignition timing—Singles	19	39
Lubrication chart	10	24
Magneto, exploded view	42	79
Oil tank	3	15
Oil filter—Twin	7	20
Oil pumps	4, 5	16, 18
Rear brake anchorage	38	73
Rectifier	40	76
Rocker adjustment	11, 12	28, 29
Sparking plug	45	83
Spring frame	30	63
Spring frame suspension	31	64
Tank fixing details	13	30
Tools	49	96
Valve spring tool	14	32
Valve timing gear	17, 20	37, 44
Wiring diagram—Singles	47	85
Wiring diagram—Twins	48	86

THE MODERN MOTOR CYCLE unquestionably provides one of the most healthy, economical and pleasant means of transport. In addition, by reason of its superb braking, high power to weight ratio and ease of control it is, if used with due care, one of the safest vehicles on the road.

It is our sincere desire that every owner should obtain from his mount the service, comfort and innumerable miles of low cost travel that we have earnestly endeavoured to build into it.

It must be borne in mind, however, that although of simple design and construction, it is nevertheless a highly specialised piece of engineering and must in consequence be intelligently and efficiently maintained in order to provide unfailing reliability.

In this book we provide non-technical instructions for carrying out all the maintenance operations likely to be called for in normal service, together with assisting illustrations.

To owners of long experience we tender apologies for the elementary nature of some of the contents of this handbook, but owners, whether novice or expert, are advised to read the contents from beginning to end.

We are at all times pleased to give owners the full benefit of our wide experience in matters relating to motor cycles of our manufacture and elsewhere will be found details of the particulars required when making enquiries of our Service Department.

Safety on the Road

IN the interest of Safety on the Road, a few words of warning will not be out of place.

The outstanding manœuverability of a motor cycle over most other vehicles on the road makes it necessary to exercise caution at all times.

There are, unfortunately, a few motor-cyclists whose reckless driving constitutes a menace not only to themselves but also to other road users resulting in the totally false impression in some quarters that motor-cycling is a dangerous pastime.

REMEMBER IT IS NOT THE MOTOR CYCLE THAT CAUSES ACCIDENTS, IT IS THE MAN WHO IS RIDING IT

Take a pride in your riding technique and never rely upon the other fellow doing the right thing.

Your example of careful and courteous riding will materially contribute to road safety and to the reputation of a fine sporting pastime.

NO ACCIDENTS PLEASE

Your motor cycle, as issued from the factory, is fitted with an efficient silencing system, and with careful and unobtrusive driving, particularly in built-up areas, will not cause annoyance to the general public.

Owners who interfere with the silencing system by removing the baffles are purely exhibitionists and such conduct can only bring motor-cyclists in general into disrepute.

- (21) **Trip mileage recorder.** The bottom set of figures located in the speedometer dial. Indicates the number of miles (or kilometres) travelled since the recorder was set to zero. Can be re-set at any time. Used to measure the length of individual trips. The red figures indicate tenths of a mile. Unless re-set, indicates a total of 1,000 miles and then automatically re-sets to zero.
- (22) **Re-set knob.** Protrudes from lower part of speedometer head. Pull and turn to right till "000-0" appears to re-set the trip mileage recorder.
- (23) **Gear indicator.** Moves under the control of the gear change lever and the number registering with a line on gear box indicates gear in engagement (or neutral).
- (24) **Pillion foot rest.** Fold upwards to a vertical position when not in use.
- (25) **Fork top bolt.** One at top of each fork main inner tube. Must be raised to allow insertion of hydraulic fluid.
- (26) **Ignition switch.**
- (27) **Valve lifter.**

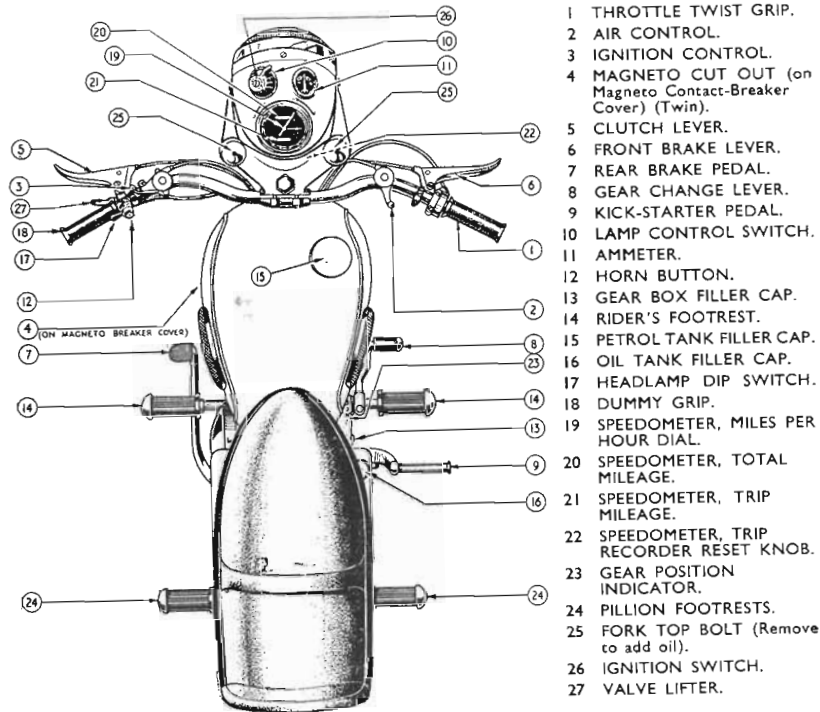

Illustration I
Controls

Before using the machine, sit on the saddle and become familiar with the position and operation of the various controls. Pay particular attention to the gear positions.

If any adjustment is made to the rear brake pedal make certain the brake does not bind and also see there is not excessive free pedal movement before the brake comes "on."

DRIVING

FUEL

Although various quality fuels are again available owners are advised to use only the best. The small economy that might be considered to accrue by using the cheaper grades is more than offset by the advantages obtained by using only Premium Grades.

FUEL SUPPLY

Two fuel feed taps are situated underneath the rear end of the petrol tank. (One each side.) Both must be shut off when the machine is left standing for more than a few minutes.

The tap plungers work horizontally. Push hexagon end *in* for ON.

Normally, only use the tap on the right hand side of the machine and then the other side will act as a reserve supply. Always re-fuel as soon as possible after-being forced to call upon the reserve and then, at once, close the "reserve" tap.

It will be noted that, by fitting two petrol feed taps, it is possible to remove the petrol tank from the machine without the necessity of first draining it of fuel.

STARTING THE ENGINE FROM COLD

Check that there is sufficient fuel in the petrol tank.

Check that there is sufficient oil in the oil tank.

Check that the gear pedal is in the neutral position.

Pull outward the plunger of off-side petrol tap.

Check that the air control lever is in the fully closed position.

Open the throttle not more than one-sixth of the total movement of the twist grip.

Depress the plunger on the top of the carburetter float chamber until it can be felt the chamber is full of petrol.

SINGLE CYLINDER MODELS

Turn ignition switch key to IGN. Open the throttle to the smallest amount possible.

Raise the valve lifter lever and, while keeping it raised, turn over the engine several times by depressing the kick-starter pedal, three times, the object being to free the engine. (This only applies if the engine is cold.)

Depress the kick-starter until compression is felt, then raise the valve lifter lever and ease the engine just over compression. Then, after allowing the kick-starter pedal to return nearly to its normal position, give it a long swinging kick with the valve closed. Flywheel momentum will carry over compression and the engine should fire immediately. If it fails to do so repeat exactly the same process.

Do not allow kick-starter to return violently against its stop.

The kick-starter mechanism must be allowed to engage properly before putting heavy pressure on the kick-starter crank pedal pin. That means there are two definite and separate movements when operating the mechanism by depressing the crank.

The first is a slow and gentle movement which ends when it is felt the pawl has engaged with the teeth on the ratchet pinion.

TWIN CYLINDER MODELS

Fully advance the ignition, then pull inwards the control lever one-eighth of an inch. Operate the kick-starter by giving it a long deliberate swinging kick and the engine should start.

The first slow and gentle movement is essential to avoid damage to the teeth of the kick-starter pinion.

After the engine has started, slowly open the air lever until it runs evenly. Then set the throttle so that the engine is running at a moderate speed (neither racing nor ticking over) and allow to warm up. While doing this, check the oil circulation as detailed in page 15. The machine can then be taken on the road.

NOTE—Do not race up the engine from cold and do not flood the carburetter to such an extent that petrol is dripping because then, in the event of a backfire, there is a danger of such loose petrol igniting. This cannot possibly happen if the starting instructions are carefully followed, but, in the event of a fire, there is no cause for panic. Merely turn off the petrol tap to isolate the main supply, open wide the throttle and turn over the engine by operating the kick-starter pedal when suction will extinguish the fire.

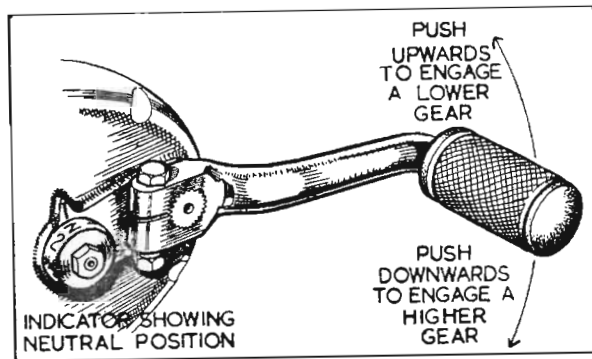

Illustration 2

Showing gear pedal indicator which upon assembly is set to record the various gears also neutral position.

Upon re-assembly after dismantling for any purpose the indicator pointer should be correctly re-set for future reference.

STOPPING THE ENGINE—SINGLES

To stop the engine, close the throttle, TURN OFF IGNITION. Before leaving the machine, turn off the fuel supply.

STOPPING THE ENGINE—TWIN

To stop the engine, close the throttle, depress the magneto cut-out press switch on the contact breaker cover and keep it depressed until the engine has ceased to revolve.

ON THE ROAD

Having started and warmed up the engine, take the machine off the stand, sit astride it, free the clutch by pulling up the large lever on the left bar and engage the lowest gear. Next, slowly release the clutch lever and the machine will commence to move forward. As it does this, the engine speed will tend to drop as it picks up the load so it will be necessary to increase the throttle opening, gradually, to keep the engine speed gently rising.

When well under way, disengage the clutch, slightly close the throttle, engage second gear and release the clutch lever, then open up the throttle to increase the speed of the machine. Repeat these operations in order to engage third and top gears.

To engage a higher gear the pedal is pressed downward with the toe and a lower gear is obtained by raising the pedal with the instep. To engage first gear from the neutral position, the pedal is therefore raised. After each pedal movement, internal springs return the pedal to its normal horizontal position.

The pedal must be moved to the full extent of its travel when selecting a gear, either up or down. It must not be "stamped down" or jabbed, but firmly and decisively moved till it stops. A half-hearted movement may not give full engagement. Keep the foot off the pedal when driving and between each gear change because, unless the lever can freely return to its normal central position, the next gear cannot be engaged.

RUNNING IN THE ENGINE

Selective assembly of parts, such as pistons, cylinders and big end assemblies, etc., are used in the process of manufacture. It is an established fact that if the engine, when new, is run in as it should be, engine trouble or seizures will not occur.

It is a natural desire to learn the capabilities of one's machine, similarly it can be irritating to be overtaken by a rider of a machine fitted with a smaller capacity engine. Nevertheless, the owner of a new machine must, in his own interest, strictly adhere to the principles of running in, which will result in a quieter engine, with a better performance than a similar machine owned by a rider who is unwilling to drive with restraint during the initial stage of running in.

The load imposed on the engine is governed by the amount of throttle that is used, and the makers of your machine, know from experience, that if the throttle or twist grip is not opened in excess of one-third of its total movement for the first 1,000 miles independent of road speed, the engine cannot be overloaded.

After this distance the amount of throttle can be progressively increased until the machine has covered 2,000 miles.

For convenience a limit mark can be used on the twist grip and grip body.

The recommendation of limiting the road speed to 30 m.p.h. is most unsuitable for running in, for with this principle the machine could be driven up hill in top gear at 30 m.p.h. and to do so three-quarter or full throttle would be used, which could seriously and unnecessarily overload the engine.

Special attention must be given, during the running in period, to such details as valve rocker adjustment, chains, brakes, contact breaker points, and steering head bearings, all of which tend to bed down in the first hundred miles or so. Particular note must be made of the adjustment of steering head bearings, which, if run in a slack condition, will be quickly ruined. After this bedding down process has taken place, adjustments to such details will only be necessary at lengthy intervals.

Do not overlook instructions for changing oil (see page 26).

NOTES ON DRIVING

If, at first, the lowest gear will not engage, release the clutch lever and after a second or two, make another attempt. This condition may exist in a new machine, but it tends to disappear after a little use.

Always endeavour to make the movements of hand (on the clutch) and foot (on the gear pedal) as simultaneous as possible, and remember, in all gear changes, a steady pressure of the foot is desirable. This pressure should be maintained until the clutch is fully released. It is not sufficient just to jab the foot pedal and then release the clutch lever.

When actually in motion, it will be found sufficient to merely free the clutch a trifle, to ease the drive when changing gear and, with reasonable care, changes of gear then can be made without a sound.

Do not unnecessarily race the engine or let in the clutch sufficiently suddenly to cause the rear wheel to spin. Take a pride in making a smooth, silent get-away.

When changing up to a higher gear, as the clutch is freed, the throttle should be slightly closed so that the engine speed is reduced to keep in step with the higher gear ratio. Conversely, when changing down to a lower gear, the throttle should be regulated so that the engine speed is increased to keep in step with the lower gear ratio.

Do not slip the clutch to control the road speed.

The clutch is intended to be used only when starting from a standstill and when changing gear. It must **NOT** be operated to ease the engine, instead of changing gear, or be held out, in order to "free-wheel."

The exhaust valve lifter is **NOT** used in normal driving on main and secondary roads.

When travelling slowly, such as may occur in traffic or on a hill, and the engine commences to labour, it is then necessary to change to a lower gear. Engine "knocking" or "pinking" and a harshness in the transmission are symptoms of such labour. A good driver is able to sense such conditions and will make the change before the engine has reached the stage of distress. The gear box is provided to be used and consequently full use should be made of the intermediate gears to obtain effortless running and smooth hill climbing.

Keep the feet clear of the brake and gear pedals when not actually using them and keep the hand off the clutch lever when not in use.

Drive as much as possible on the throttle, making the minimum use of the brakes.

When using the machine on wet or greasy roads, it is generally better to apply **BOTH** brakes together, because sudden or harsh application of either brake only, under such conditions, may result in a skid.

In all conditions, it is advisable to make a habit of always using both brakes together rather than habitually using the rear brake and reserving the front brake for emergency.

LUBRICATION

LUBRICANTS TO USE

Efficient lubrication is of vital importance and it is false economy to use cheap oils and greases. The use of multigrade oils is not recommended.

We recommend the following lubricants to use in machines of our make.

FOR ENGINE LUBRICATION

HOT above 50° F	COLD 32° F to 50° F	EXTREME COLD below freezing point (32° F)
SAE 50	SAE 30	SAE 20
Mobiloil D Castrol Grand Prix Energol SAE 50 Essolube 50 Shell X-100 Motor Oil 50	Mobiloil A Castrol XL Energol SAE 30 Essolube 30 Shell X-100 Motor Oil 30	Mobiloil Arctic Castrolite Energol SAE 20 Essolube 20 Shell X-100 Motor Oil 20/20W

NOTE—For the British Isles and much of Europe the **Cold** and **Hot** recommendations approximate to **Winter** and **Summer** conditions respectively. The **Extreme Cold** recommendations refer to wintry conditions in parts of Northern Europe, Canada, the Baltic and Scandinavian countries, and high mountainous districts where extreme cold is the average condition.

FOR GEAR BOX LUBRICATION

HOT above 50° F	COLD 32° F to 50° F	EXTREME COLD below freezing point (32° F)
SAE 50	SAE 50	SAE 30
Mobiloil D Castrol Grand Prix Energol SAE 50 Essolube 50 Shell X-100 Motor Oil 50	Mobiloil D Castrol Grand Prix Energol SAE 50 Essolube 50 Shell X-100 Motor Oil 50	Mobiloil A Castrol XL Energol SAE 30 Essolube 30 Shell X-100 Motor Oil 30

NOTE—For the British Isles and much of Europe the **Cold** and **Hot** recommendations approximate to **Winter** and **Summer** conditions respectively. The **Extreme Cold** recommendations refer to wintry conditions in parts of Northern Europe, Canada, the Baltic and Scandinavian countries, and high mountainous districts where extreme cold is the average condition.

FOR HUB LUBRICATION AND ALL FRAME PARTS USING GREASE

Mobilgrease No. 4 Castrolase Heavy Energrease C3
Esso Pressure Gun Grease Shell Retinax A. or C.D.

FOR TELEDRUALIC FRONT FORKS

Mobiloil Arctic (SAE-20) Castrolite (SAE-20) Energol SAE 20
Essolube 20 (SAE-20) Shell X-100 Motor Oil 20/20W (SAE-20)

FOR REAR CHAINS

Mobilgrease No. 2 Esso Fluid Grease Energrease A.O.
Castrolase Grease Graphited
Heated Until Just Fluid

When buying oils and greases it is advisable to specify the **Brand** as well as the grade and, as an additional precaution, to buy only in sealed containers or from branded cabinets.

CHECKING OIL CIRCULATION—ALL MODELS

Provision is made to observe the oil in circulation and it is advisable to do this before each run.

If the filler cap on the oil tank is removed the end of the oil return pipe will be noticed below the level of the filler cap orifice and the returning oil can be seen running from it. This check should be made immediately after starting the engine from cold. This is because while the engine is stationary, oil from all parts of the interior of the engine drains back into the crankcase sump, so that, until this surplus is cleared, the return flow is very positive and continuous. Therefore, if the oil circulation is deranged, the fact is apparent at once by the lack of a steady return flow.

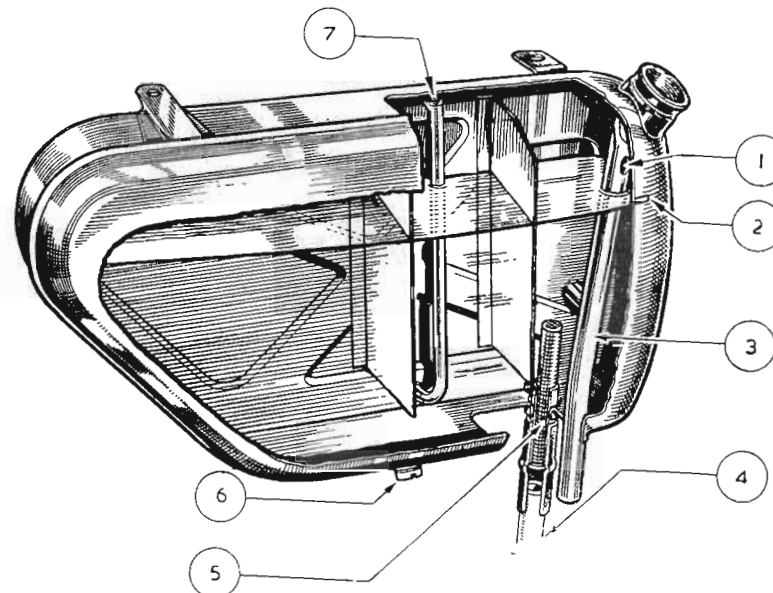

- 1 OUTLET IN OIL RETURN PIPE.
- 2 LEVEL INDICATOR LINE.
- 3 OIL RETURN PIPE.
- 4 OIL FEED PIPE.
- 5 OIL FEED GAUZE FILTER.
- 6 DRAIN PLUG.
- 7 VENT PIPE.

Illustration 3

Interior view of the oil tank showing the metal strainer mounted on the entry end of the feed pipe union, the return flow pipe from the engine to tank via the small spout, located so that it can be inspected by removing the tank filler cap, and air vent pipe, provided to ensure freedom from air-locks.

ENGINE LUBRICATION SYSTEM—SINGLES

This is by dry sump system. Oil feeds, by gravity, from the oil tank to the pump in the crankcase. The pump forces oil to various parts, which then drains to the bottom of crankcase sump. The pump then returns oil to the tank. This process is continuous while the engine is revolving. The pump is so designed that it has a greater capacity on the return side to that on the delivery side to ensure that all oil is extracted from the crankcase. A magnetic filter in the sump removes foreign matter collected by the oil in its passage through the engine. A metal gauze strainer is fitted to the oil feed pipe in the oil tank to prevent pieces of fluff, etc., which may find their way into the tank when replenishing, from entering the oil pump. (See illustration 3.) It should be cleaned in petrol each time the oil tank is drained.

SEE WARNING ON PAGE 17 BEFORE REMOVAL

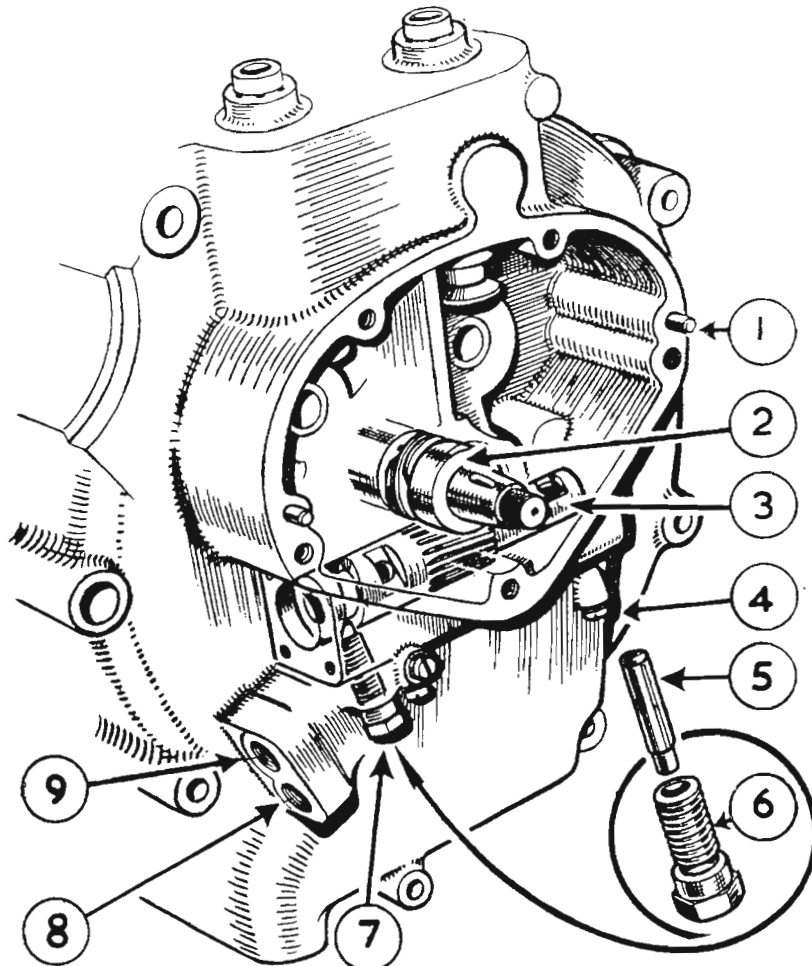

Illustration 4

The rotating oil pump plunger is here shown in situ, together with the guide screw which registers in the plunger profiled groove, thereby providing the reciprocating movement.

- | | |
|---|--|
| <p>1 DOWEL PEG, LOCATING TIMING GEAR COVER.</p> <p>2 TIMING SIDE FLYWHEEL AXLE WITH INTEGRAL GEAR FOR DRIVING OIL PUMP PLUNGER.</p> <p>3 OIL PUMP PLUNGER.</p> <p>4 SCREW (ONE OF THREE) WITH FIBRE WASHER, PLUGGING OIL PASSAGES CAST IN CRANKCASE.</p> <p>5 GUIDE PIN, FOR OIL PUMP PLUNGER. INSERTED RELIEVED TIP DOWNWARD AS SHOWN.</p> | <p>6 SCREWED BODY TO ACCOMMODATE THE OIL PUMP PLUNGER GUIDE PIN.</p> <p>7 BODY, WITH GUIDE PIN IN POSITION ENGAGED IN PROFILED CAM GROOVE OF OIL PUMP PLUNGER.</p> <p>8 TAPPED HOLE, FOR PIPE FEEDING OIL TO OIL PUMP.</p> <p>9 TAPPED HOLE, FOR PIPE RETURNING OIL TO OIL TANK.</p> |
|---|--|

ENGINE OIL PUMP (see Illustration 4)

The pump has only one moving part. This is the plunger which revolves and reciprocates. Rotation is caused by the worm gear on the timing side flywheel axle. Reciprocation is caused by the guide pin which engages in the profiled groove cut on the plunger. Oil is fed to the pump through the lower of the two oil pipes between tank and crankcase and is returned through the upper pipe.

If, for any reason, the crankcase is dismantled **the oil pump plunger must be removed from its housing before attempting to separate the crankcase halves.** It is not necessary to remove the small timing pinion which will pass through in situ.

Important

Under no circumstances must either the pump plunger or guide screw be disturbed in ordinary routine maintenance.

ENGINE OIL CIRCULATION—SINGLES

The oil pump forces oil through:—

- (a) Passages drilled through the timing side flywheel axle, timing side flywheel and crank pin to lubricate the timing side bearing and the big-end bearing. The splash passes to interior of cylinder, to lubricate the cylinder and piston, and then falls into the crankcase sump.
- (b) A passage in timing gear case where it "builds up" to a predetermined level to lubricate the timing gears and then overflows into the crankcase sump.
- (c) Through a pipe from the front of oil pump housing to the rocker box by which all rocker gear and valve stems are lubricated and then falls through the push rod cover tubes and tappet guides to the timing gear case and, from there, drains into the crankcase sump, as detailed in (b).

The oil pump extracts oil in the crankcase sump and returns it to oil tank. On its way it passes the magnetic filter located in the crankcase sump.

ENGINE LUBRICATION SYSTEM—TWINS

This is of the **dry sump** type. Two separate gear type oil pumps are used, one for delivery and the other for returning oil to the tank. Oil feeds by gravity to the delivery pump, by which it is forced, under pressure, to various parts of the engine, from whence it drains back to the crankcase sump to be collected by the return pump and returned to the tank. The return pump has a much larger capacity than the delivery pump to ensure that the crankcase is kept clear of excess oil.

ENGINE OIL PUMPS

Each pump is independently driven, at half engine speed, from the ends of the two camshafts. They each consist of a pair of close fitting gear wheels in a cast iron body. The gears of the delivery pump are considerably narrower than those of the return pump, giving the latter the necessary extra capacity to ensure efficient scavenging.

ENGINE OIL CIRCULATION—TWINS

Oil, from the oil tank, is fed by gravity, through a coarse mesh metal filter, via an external pipe, to the suction side of the delivery pump, from whence it is discharged, under pressure, to a large and easily detachable felt filter that is housed in the crankcase.

After passing through the felt filter the main supply is directed to the crankshaft centre bearing and thence, through passages in the crankshaft, to each big-end, the splash from which provides adequate cylinder lubrication.

A metered by-pass provides an oil supply to the overhead rockers and push rod ball ends which then drains into the camshaft tunnels where upon reaching a pre-determined level the surplus overflows into the timing gear case. The four drilled oilways in the cylinder heads are also intentionally metered.

A predetermined level of oil is allowed to build up in the timing case to ensure adequate lubrication of the gears, and also in the camshaft tunnels, to ensure adequate lubrication of the cams and cam levers. Upon reaching these determined levels, the surplus overflows into the crankcase, and so to the sump.

The return pump collects all surplus oil from the crankcase sump and returns it, via another external pipe, to the oil tank. (See illustration 3).

The stream of oil flowing into the tank is instantly visible upon removal of the tank filler cap.

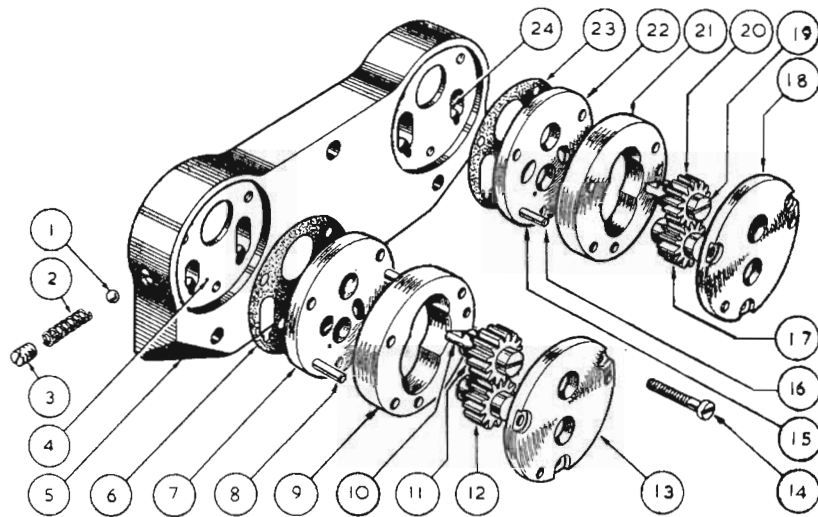

Illustration 5

Delivery Oil Pump (on the right)

- 1 BALL, FOR NON-RETURN VALVE.
- 2 SPRING, FOR NON-RETURN VALVE.
- 3 PLUG, RETAINING NON-RETURN VALVE SPRING AND BALL.
- 4 BLEED HOLE.
- 5 PLATE, CARRYING OIL FEED AND RETURN PUMPS.
- 6 PAPER WASHER FOR OIL RETURN PUMP.
- 7 BACK PLATE OF OIL RETURN PUMP.
- 8 DOWEL PIN, LOCATING PUMP PLATES AND BODY.
- 9 BODY OF OIL RETURN PUMP.
- 10 DOG END OF PUMP GEAR TO ENGAGE IN END OF CAMSHAFT.
- 11 DRIVING GEAR, FOR OIL RETURN PUMP
- 12 DRIVEN GEAR, FOR OIL RETURN PUMP.

Return Oil Pump (on the left)

- 13 FRONT PLATE OF OIL RETURN PUMP.
- 14 SCREW (1 OF 6) USED TO RETAIN PLATES AND BODIES OF OIL PUMPS TO THE CARRYING PLATE.
- 15 BACK PLATE OF OIL FEED PUMP.
- 16 DOWEL PIN, LOCATING PUMP PLATES AND BODY.
- 17 DRIVEN GEAR, FOR OIL FEED PUMP.
- 18 FRONT PLATE OF OIL FEED PUMP.
- 19 SCREWDRIIVER SLOT, TO ENABLE DRIVING GEAR TO BE CORRECTLY POSITIONED DURING ASSEMBLY.
- 20 DRIVING GEAR, FOR OIL FEED PUMP.
- 21 BODY OF OIL FEED PUMP.
- 22 BACK PLATE OF OIL FEED PUMP.
- 23 PAPER WASHER FOR OIL FEED PUMP.
- 24 BLEED HOLE.

THE OIL TANK—ALL MODELS

The level of oil in the supply tank should never be allowed to fall below the low level mark and, upon replenishment, should not be higher than the upper mark line, at which level the oil content is 4 pints.

After the first 500 miles, again at 1,000 miles, and subsequently at 5,000 mile intervals, it is recommended that the oil tank is drained, the oil filter cleaned in petrol and the tank replenished with new oil.

THE OIL FILTERS

There are three filters for the oil.

- (A) The metal filter located in the feed pipe in the bottom of the oil tank. This is a thimble shaped filter of coarse metal mesh inserted, from the exterior, in the short metal feed pipe located in the bottom of the oil tank. It has an open end finished with a turned over metal ring, located by the oil feed pipe.
- (B) The felt fabric filter located in a chamber in the front part of the crankcase and parallel to the exhaust camshaft. This is a cylindrical filter made of close grain felt that is supported by a tubular wire cage.

On the inner end is fitted a steel cup which effectively seals that end of the cylindrical filter. This cup is a push on fit.

In the outer end is inserted an aluminium plug, or valve, which acts as a relief valve, allowing the oil to escape if, for any reason, it cannot percolate through the felt fabric. In normal conditions this valve does not operate but, if for example, the cleaning of the filter had been neglected to such an extent that it was so clogged the oil could not pass through it in the volume supplied by the pump, then the valve would lift to give immediate temporary, or permanent, relief, as may be necessary.

(C) The magnetic filter in the crankcase oil sump.

NOTE—Filter B is used on twin cylinder models only.

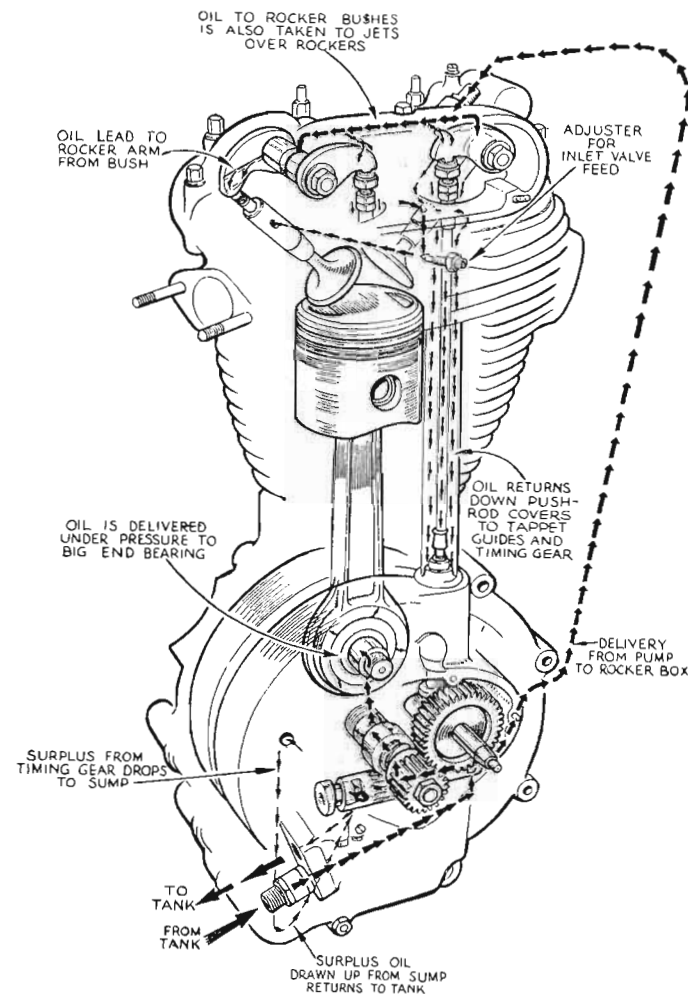

Illustration 6

Engine Oil Circulation

ADJUSTMENT OF OIL FEED

The internal flow of oil is regulated by fixed restrictions. No adjustment is provided except for the oil feed to the inlet valve stem. This adjustment is made by a needle pointed screw located in the right side of cylinder head. (See illustration 16). It is locked in position by a nut. The approximate correct setting is one-sixth of a complete turn from the fully closed position. Once set it requires little, or no, adjustment.

Inlet valve squeak indicates the oil feed adjustment is not open enough. Excessive oil consumption, a smoky exhaust or an oiled sparking plug, generally indicates the oil feed adjustment is open too much.

EXHAUST VALVE STEM LUBRICATION

The exhaust valve stem is lubricated by oil flowing through a passage drilled in the cylinder head. No adjustment is provided.

CLEANING OIL FILTERS—ALL MODELS

To remove and clean the feed pipe metal filter :

Drain Tank.

Then remove the oil feed pipe from the metal feed pipe protruding from the bottom of the oil tank.

The metal filter may come away with the feed pipe, in which case there is no need to disturb it. On the other hand it may remain in the oil tank bottom pipe, in which case it may be withdrawn by grasping the ringed open end and pulling away.

After removal the filter should be cleaned in petrol and allowed to dry before re-fitting.

Reverse the above procedure to re-fit the filter and pipes.

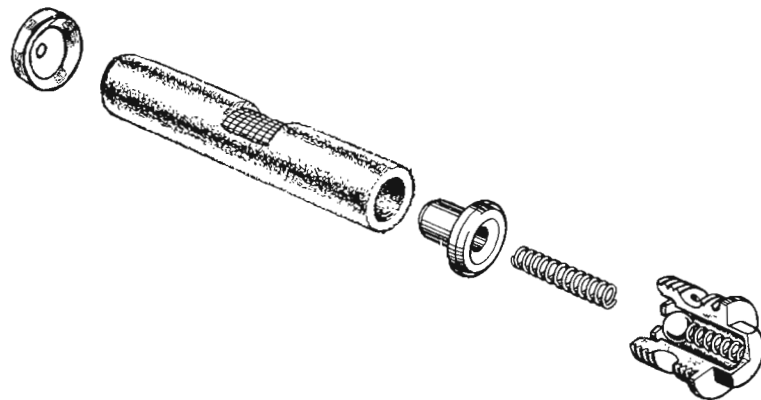

Illustration 7

Twin crankcase filter assembly

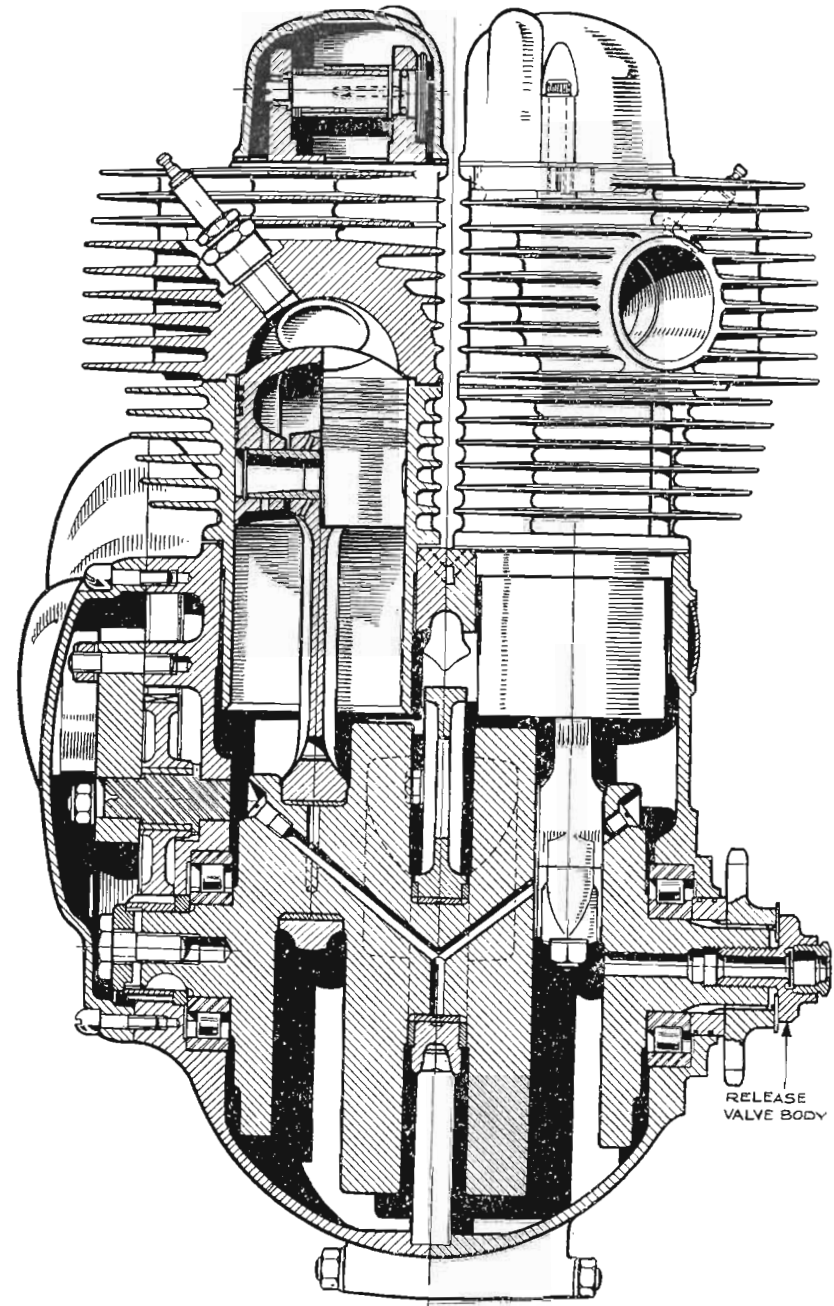

Illustration 8

Cross section of engine showing oil galleries, oil passages, and release valve.

To remove and clean the felt crankcase filter—Twins :

Unscrew and remove the non-return valve complete (023331) (See illustration 9). Withdraw the spring which removal of the non-return valve will expose also withdraw the aluminium cap into which this spring is recessed.

This will expose the felt fabric filter which can be withdrawn by inserting a finger in the open end. In the other end of the filter is a steel cup which should be pulled away from the filter.

The filter should be cleaned in petrol and allowed to dry before re-insertion.

The housing tunnel for the filter should also be thoroughly cleaned out with a fluff-free rag moistened in petrol.

Reverse the above procedure to re-fit the felt filter and, when doing so, do not forget to replace the steel cup on the open end of the filter before inserting it in its housing tunnel.

If the filter is difficult to extract, the taper handle of a paint brush, inserted in the filter aperture, will facilitate removal.

Avoid scruffing the filter fabric, as the filter passes the threaded hole in the crankcase.

Particles of this material can cause obstruction in the drilled oilways, if it is not removed before re-fitting the filter.

TO REMOVE MAGNETIC FILTER—ALL MODELS

Incorporated with the crankcase sump plug is a powerful magnet, which does not require frequent attention. For cleaning place a tray under the crankcase, unscrew the sump plug, with the use of a good fitting ring spanner.

Metal particles adhering to the magnet can be removed by wiping with a grease coated rag, the grease will collect metal particles on the rag. Keep the magnet away from large pieces of steel or iron, as contact can impair the efficiency of the magnet.

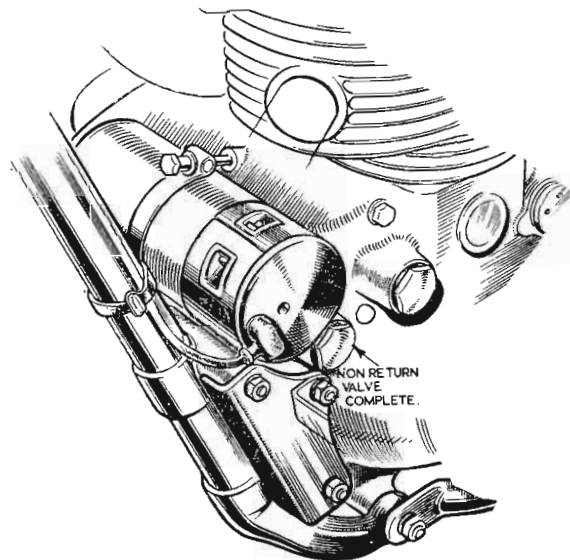

Illustration 9

Location of oil non-return valve.
Remove the valve to gain access to oil filter.

TO DISMANTLE AND REFIT CRANKCASE RELEASE VALVE IN CRANKSHAFT (see Illustration 8)

Upon removal of the outer portion of front chaincase as described elsewhere, the release valve will be observed on the end of the engine shaft.

The larger hexagon, is the release valve body, which also secures the engine sprocket.

The smaller hexagon is the release valve screw, which retains the diaphragm.

To inspect release valve and ensure correct re-assembly it is essential to remove the valve body from the engine shaft, then the valve screw can be removed.

When re-fitting diaphragm, hold the valve body vertical with large hole uppermost, when the valve screw is assembled.

GEAR BOX LUBRICATION

Use one of the grades of Oils specified. In no circumstances must heavy grease be used.

Lubricant is inserted through the filler cap orifice mounted on top edge of kick-starter case cover.

The gearbox must not be entirely filled with oil. An excess will cause leakage. Check the level every 1,000 miles and top-up if necessary.

A screwed drain plug in gear box shell, low down at rear, facilitates gear box flushing and change of lubricant.

An oil level plug, adjacent to K.S. spindle, indicates maximum permissible oil level (content 1 pint).

CHAIN LUBRICATION

The front driving chain runs in oil bath. (Front chaincase.)

Use engine oil to lubricate and maintain level to just below the chain inspection cap orifice.

A sliding oil seal in the form of two steel discs surround the gearbox mainshaft.

To remove inspection cap use spanner 018178 in slot machined in the cap.

A drain plug is used so that oil can be changed without disturbing the outer portion of the chaincase.

Rear driving chain should be removed occasionally for lubrication particularly under winter conditions.

Clean chain in paraffin, allow to drain and wipe. Then immerse in one of the greases recommended, heated to just fluid state. Leave in soak for at least ten minutes while maintaining grease fluidity. Then hang to drain off surplus and replace.

Engine oil is a poor substitute for one of the recommended greases and if used the chain should be allowed to soak for several hours to ensure penetration to all joints, hanging to drain off surplus before re-fitting.

See chain removal and re-fitting instructions, page 57.

HUB LUBRICATION

Keep hubs packed with grease. This prevents entry of water and dirt. Grease nipple accessible through hole in side hub disc. Inject small quantity of grease. Excessive grease may impair efficiency of brakes.

BRAKE DRUM BEARING

The independent ball bearing upon which the rear brake drum is mounted, is packed with grease upon assembly and requires no further attention for a considerable time.

During a general overhaul however it is recommended that the bearing is dismantled and re-packed with fresh hub grease.

LUBRICATION CHART

The figures in diamond frames refer to parts located on the left hand side of the machine and those in circles refer to parts located on the right hand side, and apply to both single and twin cylinder models.

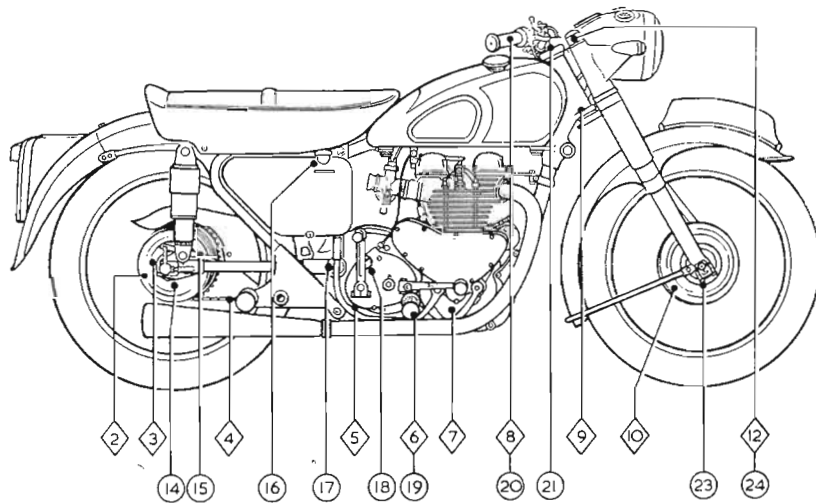

Illustration 10
Lubrication Chart

Engine Oil Locations

- 16 MAIN OIL TANK.
- 7 FRONT CHAINCASE.
- 8 } CONTROL LEVER MOVING PARTS.
- 20 }
- 2 BRAKE ROD JOINTS.
- 6 } CENTRE AND PROP STAND HINGE PINS.
- 19 }

Hydraulic Fluid Locations

- 12 } FRONT TELEDRYRAULIC FORKS.
- 24 }

Heavy Engine Oil Location

- 18 GEAR BOX.

Grease Locations

- 23 FRONT HUB.
- 14 REAR HUB.
- 21 STEERING HEAD TOP BEARING.
- 9 STEERING HEAD BOTTOM BEARING.
- 15 SPEEDOMETER GEAR BOX.
- 10 FRONT BRAKE EXPANDER.
- 3 REAR BRAKE EXPANDER.
- 5 BRAKE PEDAL SPINDLE.

Heavy Gear Oil Location SAE-140

- 17 REAR FORK HINGE.

Molten Grease Location

- 4 REAR CHAIN.

When buying oils and greases it is advisable to specify the **Brand** as well as the grade and, as an additional precaution, to only buy in sealed containers or from branded cabinets.

BRAKE EXPANDER LUBRICATION

Grease nipple on each brake expander bush. (One on each brake cover plate.) Use grease sparingly. Excessive grease may impair efficiency of brakes.

BRAKE ROD JOINT LUBRICATION

A few drops of engine oil on each brake rod yoke end pin and on the threaded portion of brake rod. (One pin on yoke each end of brake rod and on bottom of front brake cable.)

BRAKE PEDAL LUBRICATION

Grease nipple in heel of foot brake pedal.

SPEEDOMETER LUBRICATION

One grease nipple on top of speedometer gear box attached to right side of rear wheel spindle. (No other part of the speedometer requires lubrication.)

STEERING HEAD BEARING LUBRICATION

One grease nipple on front frame head lug and another on right hand side of handlebar lug.

CONTROL LEVER LUBRICATION

Occasionally a drop of engine oil on all moving parts of the handlebar control levers. If twist grip is too stiff : remove two screws binding the two halves of the clip. This releases the grip which may be pulled off the handlebar. Smear handlebar, the drum on which the inner wire is wound and the friction spring on the half clip with grease and replace.

REAR FORK HINGE

Heavy Gear Oil SAE 140 (see page 63).

MAINTENANCE

PERIODICAL MAINTENANCE

Regular maintenance attention to lubrication and certain adjustments must be made to ensure unfailing reliability and satisfactory service. This necessary attention is detailed below and owners are strongly recommended to carefully follow these suggestions and to make a regular practice of doing so from the first.

The reference numbers, in brackets, refer to the locations specified on the Lubrication Chart, illustration 10, page 24.

DAILY

- Oil tank** Inspect oil level (16) and top-up to top line level if necessary. Check oil circulation.
- Petrol tank** Check level and re-fill if necessary.

WEEKLY

- Oil tank** Check level and re-fill to top line level if necessary. (16)
- Tyres** Check pressures and inflate if necessary.

EVERY 500 MILES

- Oil tank** Drain at first 500 miles and re-fill to top line level with new oil, and clean filter. (16)
- Ignition** Check contact breaker points.
- Gear Box** Drain at first 500 miles and re-fill (18) 1 pint.
- Chaincase** Check level of oil when machine is standing vertically on level ground when level of oil should be just below bottom edge of inspection orifice (7). Fill up if level is low.
- Battery** Inspect each cell for level of electrolyte and top up with distilled water if necessary. Level of electrolyte should just be over top of plates. Beware of overfilling.

EVERY 1,000 MILES

- Oil tank** Drain at first 1,000 miles and re-fill with new oil. (16)
- Rear chain** In wet weather remove and soak in molten grease. See page 14. (4)
- Gear box** Add 2 fluid ounces of specified oil. (18)
- Hubs** Inject small amount of grease. (14-23)
- Expanders** Inject small amount of grease. (3-10)
- Steering head** Inject small amount of grease. (9-21)
- Small parts** Smear all moving parts with engine oil and wipe off surplus. (2-6-8-19-20).
- Chaincase** Drain, and refill, or monthly.

EVERY 2,000 to 5,000 MILES (according to road conditions)

- Air Filter** (If fitted) clean and re-oil filter element.

EVERY 3,000 MILES

- Rear chain** In dry weather remove and soak in molten grease. (4)
- Brake pedal** Inject small amount of grease. (5)
- Speedometer** Inject small amount of grease into speedometer gear box. (15)
- Ignition** Clean contact breaker points and re-set if necessary.
- Plugs** Clean sparking plugs and re-set points as necessary. When re-fitting reverse respective positions.
- Steering head** Test steering head for up and down movement and adjust if necessary.
- Bolts and nuts** Check all nuts and bolts for tightness and tighten if necessary but beware of over-tightening.
- Rockers** Check O.H.V. rocker adjustment and correct if necessary.

EVERY 5,000 MILES

- Oil tank** Drain and re-fill with new oil. (16). If machine is only used for short runs renew oil every three months instead of mileage interval.
- Filters** Clean metal mesh filter in oil tank (illustration 3), and felt fabric filter in crankcase on twins.
- Ignition** Clean and adjust as detailed in Electrical section.
- Dynamo** Clean as detailed in Electrical section.
- Front fork** Check each side of front fork for hydraulic fluid content and, if necessary, top up. (12-24)
Insufficient oil content is indicated by abnormally lively action.
- Carburetter** Remove carburetter float chamber side cover and clean interior. Also detach petrol pipe banjo and clean gauze strainer.

EVERY 10,000 MILES

- Magneto and Dynamo** Get a **Lucas Service Station** to dismantle, clean, lubricate and generally service.
- Air Filter** (If fitted) renew filter element.

ENGINE SERVICE

TAPPET ADJUSTMENT—SINGLES

The top ends of the two long push rods have screwed extensions. These are locked in position by nuts, thereby providing tappet adjustment.

The correct tappet clearances, on all models, with valves closed and engine warm (not hot) is **NIL**. This means the push rods should be free enough to revolve and, at the same time, there should be no appreciable up and down play.

Prepare to adjust tappets by :

Set piston to T.D.C. (both valves closed).

Remove the three nuts, and fibre washers under them, retaining tappet cover to rocker box.

Take away cover.

Adjust tappets on all 350 and 500 models by :

With spanners, hold the sleeve 5, either valve (illustration 11) and slacken lock nut 2.

Then screw, in or out, the head 3 until the clearance is nil.

Tighten lock nut 2 and re-check the clearance.

Finally

Check adjustments so that, with no up and down movement, the long push rods are free to revolve when the valves are closed.

Illustration 11

Tappet adjustment

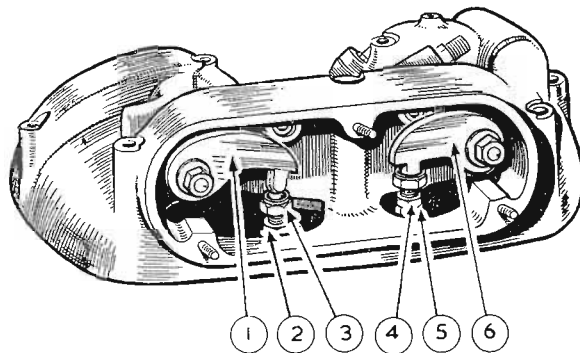

- | | |
|--|---|
| 1 INLET ROCKER ARM (TAPPET END). | 4 CUPPED ADJUSTING SCREW AND LOCK NUT. |
| 2 NUT, LOCKING ADJUSTING CUPPED SCREW. | 5 SLEEVE, TO ACCOMMODATE ADJUSTING SCREW, ON TOP END OF PUSH ROD. |
| 3 CUPPED ADJUSTING SCREW | 6 EXHAUST ROCKER ARM (TAPPET END). |

Complete adjustment by :

Replace rocker tappet cover taking care to replace the fibre washer that is under each retaining nut.

As mentioned elsewhere do not over-tighten the nuts because the joint is made with a rubber fillet and undue pressure is not necessary.

NOTE—In normal conditions tappet adjustment should not be necessary more frequently than about every five thousand miles or after decarbonising and grinding valves. If adjustment is found necessary more frequently the cause should be investigated at once.

The tappet rods are made of Light Alloy, and in manufacture, the sleeve marked 5 in illustration 11 is fitted to the bare rod and then the push sleeve and the rod are threaded to take the adjusting screw marked 3.

It will consequently be seen that, contrary to the practice when steel rods are used, it is not possible to supply and fit sleeve 5 to an existing light alloy rod.

Consequently the "Push Rod, bare" will only be supplied for spares purposes complete with sleeve 5 already fitted and threaded.

TO ADJUST OVERHEAD ROCKERS (Tappet Clearance)—TWINS

Using key bar 018055 remove screws securing a rocker cover. (It is desirable to deal only with one cover at a time.)

Lift off the cover, exposing the rocker.

Using single-ended spanner 015264, slightly slack off the nut of the bolt clamping the disc headed end of the rocker spindle. (See note below.)

Then slowly revolve the engine, by means of the kick-starter pedal, till well past the position at which the valve closes and then proceed to revolve the rocker spindle until the correct clearance is obtained, whereupon, re-tighten the locking nut and replace the cover. (Inspect gasket under rocker cover and, if damaged, replace with new.)

The correct rocker clearance, with cold engine, is .006" for both inlet and exhaust.

It is best to ensure that each piston, in turn, is at the top of its firing stroke when adjusting rocker clearances. The method of obtaining that position is explained in the paragraph dealing with **Timing the Ignition**. This piston position is essential to ensure the cam levers are well clear of the cam quietening curves when adjusting rocker clearance.

It should, perhaps, be explained here that these quietening curves, as they are called, are actually slight inclines from the base circles of the cams to the foot of each hump and their object is to slowly take up the clearance between the cam levers and valve push rods as the valves open and close thus reducing noise.

NOTE—If the rocker spindle clamping bolt nut is unscrewed to an unnecessary extent the rocker spindle will then move sideways, under the influence of the spring washer, and then the thrust washer at the end of the rocker spindle may drop out of exact location and, unless noticed and re-positioned, damage to the flanged end of the rocker spindle may result upon re-tightening the clamping bolt nut. Care to avoid this is necessary. (See illustration 12).

- 1 PLAIN WASHER—MENTIONED ABOVE.
- 2 SPRING WASHER.
- 3 PLAIN WASHER.
- 4 ROCKER.
- 5 CYLINDER HEAD.
- 6 ROCKER CLEARANCE .006".
- 7 VALVE SPRING CAP.
- 8 CLAMPING BOLT NUT.
- 9 CLAMPING BOLT WASHER.
- 10 CLAMPING BOLT.
- 11 CUTAWAY ON ROCKER SPINDLE
- 12 ECCENTRIC ROCKER SPINDLE.

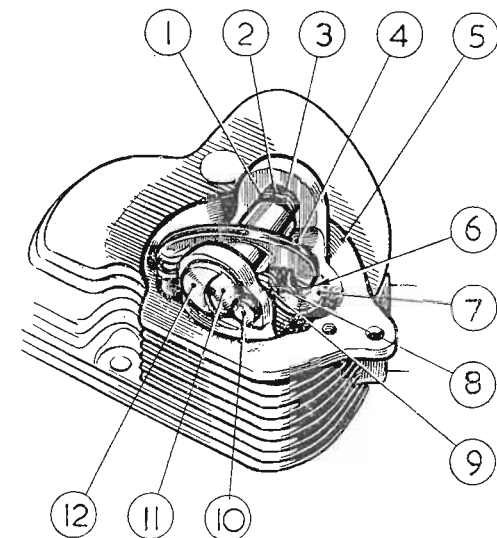

Illustration 12

Rocker Adjustment

For all service work to the upper part of the engine, other than adjustment of the rockers, it is necessary, in order to obtain accessibility, to first remove the petrol tank. The two petrol taps facilitate this operation by removing the need to drain the tank of petrol.

TO REMOVE TWIN SEAT

Remove both screws at rear of seat, release nuts for front mounting, seat can then be taken away.

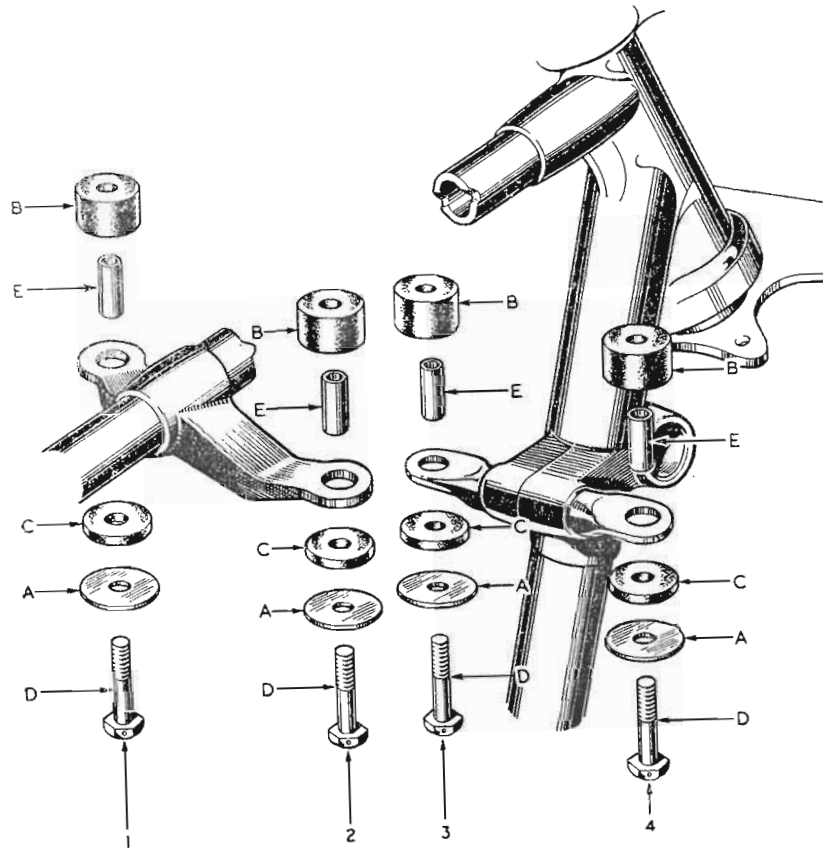

Illustration 13

TO REMOVE THE PETROL TANK

Close both petrol taps and remove the cap nut securing each petrol pipe banjo connector. Use two spanners, one to hold the tap and the other to unscrew the cap nut. Beware losing the fibre washers (4 in all) fitted one each side of each banjo connection. Cut the wires interlacing the four fixing bolts.

Remove the tank fixing bolts and the tank is then free to be taken away.

NOTE—The disposition of the various rubber and metal washers and tubular spacers should be specially observed so that they may be correctly replaced.

TO REPLACE THE PETROL TANK

Proceed in reverse order to removal. Screw firmly home the four fixing bolts and interlace them, in pairs, with 22 gauge copper wire.

DECARBONISATION

Instead of the usual stipulated mileage interval between periods of decarbonisation, it is recommended that this is undertaken only when the need for same becomes apparent because of loss of power, heavy petrol consumption or generally reduced performance. When undertaken, unless it is thought necessary to inspect the piston and rings, the cylinder barrel/s are best left undisturbed.

The various stages in decarbonisation are described.

SINGLE CYLINDER MODELS

TO REMOVE THE ROCKER BOX

Remove the petrol tank.

Remove the three nuts and fibre washers retaining the rocker box side cover and take away the cover.

Disconnect the oil pipe feeding oil to the rocker box.

Turn over engine until both valves are completely closed.

Remove engine steady bracket by removing bolt from frame clip and nuts and washers from the rocker box bolt extensions.

Remove the nine bolts retaining rocker box to cylinder head.

Disconnect valve lifter cable.

Tilt upward the right hand side of rocker box and extract the two long pushrods. Lay these aside so they may be identified and replaced in their original position.

The rocker box may then be lifted off.

TO REPLACE THE ROCKER BOX

Carefully clean the top of cylinder head and lower face of rocker box.

Revolve engine until both tappets are down, i.e., the top dead centre of firing stroke.

Lay the composition jointing washer on cylinder head. This must be faultless. If necessary, renew.

Lay the rocker box in position then slightly raise the right hand side to allow the long push rods to be inserted into their original respective positions.

Insert all nine rocker box firing bolts and note that the bolt with short head is in the centre right hand position and the bolts with threaded extensions are fitted one each side of the central short head bolt.

Tighten each bolt in turn bit by bit until all are fully home.

Replace the engine steady stay.

Turn engine over several times to ensure parts have bedded home.

Re-fix valve lifter cable.

Re-fix rocker box oil pipe union nut using two spanners to ensure that the union screwed into rocker box does not turn while the nut is being tightened.

Check tappet clearances and re-set if necessary.

Inspect rubber fillet on rocker box side cover and renew if not perfect.

Replace the side cover ensuring that a fibre washer is fitted under each of the three retaining nuts.

Beware of over tightening these nuts, the joint being made by the rubber fillet excessive pressure is not necessary.

TO REMOVE THE CYLINDER HEAD

Remove

The petrol tank.

The sparking plug. See note on page 32.

The rocker box.

Remove the exhaust system by :

Remove nut, and washers, retaining exhaust pipe to its stay.

Remove nut, and washers, retaining silencer to its stay.

Remove complete exhaust system, by pulling away from stays and then downwards, from the exhaust port in cylinder head.

Remove carburetter by :

- Air filter connection.
- Unscrew two carburetter retaining nuts.
- Take away carburetter and lay aside.

Remove

The four bolts retaining cylinder head to barrel, and head is free to be taken away. While doing this the push rod cover tubes will come away with the head.

NOTE—If the sparking plug resists removal, do not use force but brush penetrating oil round the body and leave for a time to soak before making further effort.

TO REMOVE AND REPLACE THE VALVES AND GUIDES

- Remove the cylinder head.
- Remove the valve springs by inserting a finger in the spring coil and sharply pull upward.
- The top spring collar and split collet can then be removed leaving the valve free to be withdrawn.
- A sharp light tap on the valve collar may be necessary to free the taper split collet. It will be observed that the valve spring seat has a raised impression on its under side which registers with a hole drilled on the valve guide boss to ensure accurate positioning.
- To remove an inlet valve guide, thoroughly clean protruding end of guide to be removed.
- Apply gentle heat and press guide downwards. To remove an exhaust valve guide, apply gentle heat, press the guide upwards sufficiently to permit removal of the external circlip. Then, clean the top of the guide, and press downwards to remove. Re-heat when replacing and see that correct projection is obtained, viz. $\frac{1}{2}$ ". Also see that oil hole in guide is in correct alignment.

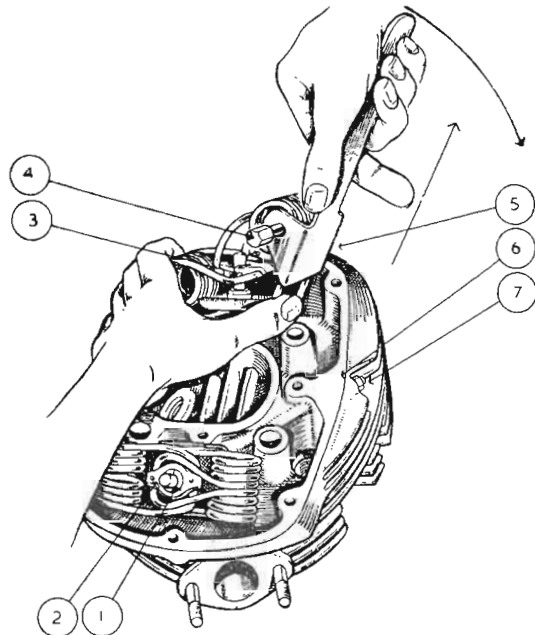

Illustration 14

Application of valve spring compressor

- | | |
|---|--|
| <ul style="list-style-type: none"> 1 COLLET, FOR VALVE. 2 COLLAR, FOR VALVE SPRING. 3 COLLAR, FOR VALVE SPRING. 4 BOLT THROUGH TOOLS AND COILS OF VALVE SPRING. | <ul style="list-style-type: none"> 5 VALVE SPRING COMPRESSOR TOOL. 6 OIL PASSAGE FROM ROCKER BOX TO INLET VALVE GUIDE. 7 SCREW WITH LOCK NUT ADJUSTING OIL FEED TO INLET VALVE. |
|---|--|

NOTE—The special valve spring compressor tool is not part of the standard tool kit but can be obtained from any of our dealers (Part No. 018276.)

It is essential that the collets are correctly located on the valve stems. It will be observed that the collet has two grooves machined in the bore and those two grooves must register with the two rings on the valve stem. If fitted so that only one of the grooves engages the ringed valve stem, damage will almost certainly result.

On 350 c.c. the inlet valve head is larger in diameter than the exhaust. Therefore unintended interchange is not possible.

On 500 c.c. both valve heads are identical in dimensions but are made of different materials. Therefore, upon removal, valves should be laid aside so that they may be identified for re-fitting. In case of doubt, see marking "In" or "Ex" on stem adjacent to collet grooves.

TO REPLACE A VALVE

After cleaning valve guide bores, smear each valve stem with clean oil, insert, and apply top collar and split collet.

Then apply the valve springs which although possible to fit by hand are more easily manipulated with a special compressor tool Part No. 018276, illustration 14. To operate this tool apply the top end of the valve spring to its groove in the top cap, then insert a short rod (one of the rocker box fixing bolts suits admirably) through the holes in this tool and the valve spring coils and pull outward and upward until the ends of the prong of the spring can be rested on the seat, then press down with the fingers. Withdraw the bolt or rod when the compressor lies against the cylinder head, retaining pressure with the fingers until the bolt has been withdrawn and the tool removed, when the spring can be readily pushed down to its proper location with the prongs laying flat upon the seat.

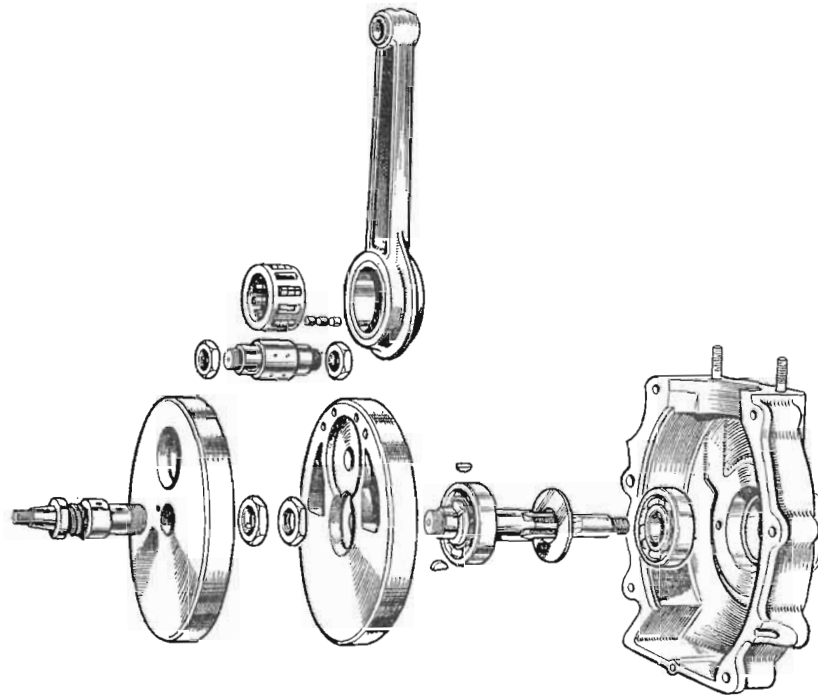

See technical data for shaft location

Illustration 15—Flywheel assembly

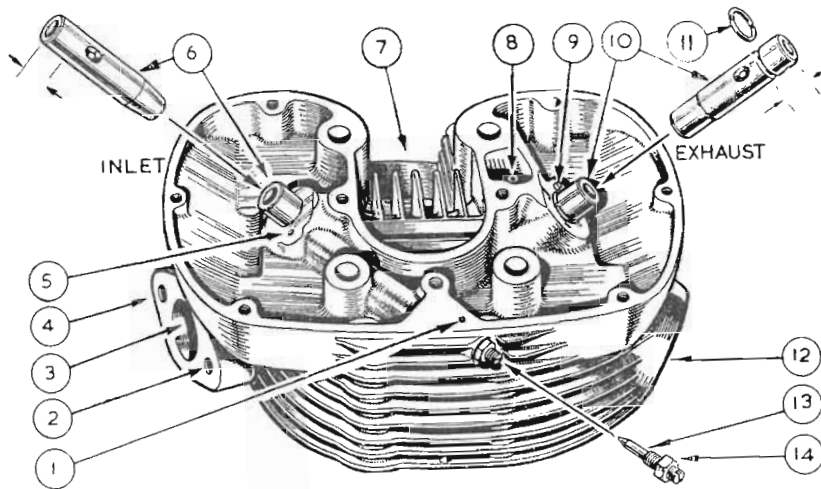

Illustration 16

The valve guides and the needle adjusting screw are also shown withdrawn

- | | |
|---|--|
| 1 PLAIN HOLE, FOR OIL FEED TO INLET VALVE. | 8 PLAIN HOLE, FOR OIL FEED TO EXHAUST VALVE. |
| 2 TAPPED HOLE, TO ACCOMMODATE CARBURETTER RETAINING STUD. | 9 HOLE, TO ACCOMMODATE DOWEL PIN LOCATING VALVE SPRING SEAT. |
| 3 INLET PORT. | 10 GUIDE, FOR EXHAUST VALVE. |
| 4 TAPPED HOLE, TO ACCOMMODATE CARBURETTER RETAINING STUD. | 11 CIRCLIP. |
| 5 HOLE, TO ACCOMMODATE DOWEL LOCATING VALVE SPRING SEAT. | 12 EXHAUST PORT. |
| 6 GUIDE, FOR INLET VALVE. | 13 NEEDLE SCREW, ADJUSTING OIL FEED TO INLET VALVE. |
| 7 TAPPED HOLE, OR SPARKING PLUG. | 14 LOCK NUT, FOR NEEDLE ADJUSTING SCREW. |

REMOVING CARBON DEPOSIT

A cheap 6" steel rule is suitable for this purpose. The use of emery cloth or similar abrasives are not recommended to remove carbon deposit.

VALVE GRINDING

The grinding is accomplished by smearing a thin layer of fine grinding paste (obtainable ready for use at any garage) on the valve face and then, after inserting the valve in the head, partially revolve, forwards and backwards, while applying light finger pressure to the head, raising the valve off its seat and turning to another position after every few movements. (Never revolve the valve continuously in one direction.)

When the abrasive ceases to bite, remove the valve and examine its face.

The grinding may be considered to be satisfactorily completed when a continuous matt ring is observed on both valve face and seat.

After grinding, all traces of abrasive must be carefully washed off with petrol and a piece of rag, moistened in petrol, should be pulled through the bore of each valve guide to remove any abrasive that may have entered.

A holder for the valve, when grinding in the valve, can be supplied. The part number is 017482.

TO REPLACE THE CYLINDER HEAD—SINGLES

A gasket is fitted between cylinder head and barrel.

The top ends of the push rod cover tubes have rubber gaskets between tubes and head, they are a push fit and metal washers are located between the top edges of the gaskets and the cylinder head recesses. If the cover tubes are pulled away from the head, the gaskets will probably remain in position in the head.

A rubber gland is fitted at the bottom of each cover tube.

Replace the cylinder head by :

Carefully clean the top edge of the cylinder barrel and the under face of the cylinder head.

Fit the cover tubes, with their rubber gaskets and metal washers, into the cylinder head.

Place the cylinder head gasket in position on the top edge of the cylinder barrel.

Place a rubber gland round each tappet guide.

Place the cylinder head in position.

Ensure each cylinder head securing bolt has a plain steel washer on it and then replace the bolts and engage each a few turns.

Finally, screw down the cylinder head securing bolts, in turn, bit by bit, until all are fully home.

Replace

The sparking plug, but before doing so it is desirable to coat thread with "Oil Dag" or graphite paste to prevent seizure upon next removal.

The rocker box, carburetter, exhaust system, and the petrol tank.

NOTE—If old gaskets are re-fitted they must be in an undamaged state otherwise new must be used.

Whether new or re-used, the gasket should be annealed just prior to fitting. This is done by heating to "blood red heat" and plunging into clean cold water.

TO REMOVE THE CYLINDER BARREL AND PISTON

Remove

The cylinder head.

The four nuts retaining cylinder barrel to crankcase.

Take away

Cylinder barrel. (Ensure piston is not damaged in doing this. Steady piston with hand as barrel is withdrawn.)

Fill throat of crankcase with clean rag to prevent entry of foreign matter.

Remove

One gudgeon pin circlip. It is immaterial which circlip is removed. Use special pliers included in tool kit.

Gudgeon pin by pushing it out of piston.

Take away piston.

NOTE—The gudgeon pin is an easy sliding fit in both piston and connecting rod small-end bush.

Rings may be removed from a piston by introducing behind the rings three pieces of thin steel spaced at 120° from each other and then sliding off the rings. (Do not scratch the piston.)

TO REPLACE THE PISTON AND CYLINDER BARREL

All parts must be clean.

Place rings on piston, scraper first then the two compression rings. On all models the top compression ring is chromium plated.

These chrome plated rings have a slightly tapered exterior and when new are clearly marked with the word TOP on one side to indicate assembly position. After use this word tends to become indiscernable, but over a large mileage the assembly position can be determined by brightness of the edge contacting cylinder wall. This bright edge is the lower one. When as the result of wear, contact with the cylinder wall appears uniform over the whole width of the ring, it is then immaterial which way round it is re-fitted.

Smear gudgeon pin with engine oil.

Refit piston by :

Introduce piston over connecting rod, so that slit in piston faces to the front of the machine.

Introduce gudgeon pin in piston and pass it through connecting rod small-end bush and centralise it.

Re-fit circlips. (Use special pliers). Use rotary action when bedding circlips in their grooves and make sure each circlip lies snugly in its groove. This is **essential** otherwise considerable damage will result.

Re-fit cylinder barrel by :

Take new cylinder base washer. Coat one side with liquid jointing compound and apply it to cylinder base.

Smear cylinder bore and piston with clean engine oil.

Space piston rings so that the gaps are evenly spaced at 120° to each other.

Gently fit barrel over piston and carefully compress each ring in turn, with the fingers, as it enters the chamfered mouth of the barrel.

Remove rag from crankcase throat.

Replace cylinder barrel holding down nuts, screwing each down, in turn, bit by bit, till all are fully home.

CAM CONTOUR

On the flanks of the cams are quietening curves which are very slight inclines from the base circles to the feet of the humps.

Therefore, it is necessary to ensure the tappet ends are on the base circles when checking valve clearances and valve timing.

It is for this reason valve clearances must be checked when the piston is at the top of its compression stroke, at which position both tappets are well clear of the quietening curves.

VALVE TIMING

Taken with valve .001" off its seat.

Inlet valve timing

Inlet valve opens 36° before top dead centre—350 c.c. models.

Inlet valve opens 18° before top dead centre—500 c.c. models.

Inlet valve closes 51° after bottom dead centre—350 c.c. models.

Inlet valve closes 69° after bottom dead centre—500 c.c. models.

Exhaust valve timing

Exhaust valve opens 50° before bottom dead centre—All models.

Exhaust valve closes 30° after top dead centre—All models.

(See page 95 for particulars of special timing disc graduated in degrees.)

Camshaft timing marks

Use mark 1 for exhaust cam—all touring models.

Use mark 2 for inlet cam—500 c.c. touring and competition models.

Use mark 2 for exhaust cam—all competition models.

Use mark 3 for inlet cam—350 c.c. touring models.

When checking the valve timing the tappet clearances must be set to .016" so that the tappets may be well clear of the quietening curves of the camshafts.

The timing gears are marked to facilitate their replacement.

To reset the valve timing, by using the marks on the gears, proceed as follows :—

Turn over the engine till the mark on the small timing pinion is in line with the centre of the inlet (rear) camshaft bush. Insert the inlet camshaft so that the No. 2 or No. 3 mark on it is in mesh with the mark on the small timing pinion, according to model. Rotate the engine in a **forward** direction till the mark on the small timing pinion is in line with the centre of the exhaust (front) camshaft bush. Insert the exhaust camshaft so that the No. 1 mark on it is in mesh with the mark on the small timing pinion.

SMALL TIMING GEAR PINION—SINGLES

This pinion is a taper fit and keyed on to the timing side shaft, the retaining nut has a **LEFT HAND THREAD**.

The timing mark on the pinion is central with the key way.

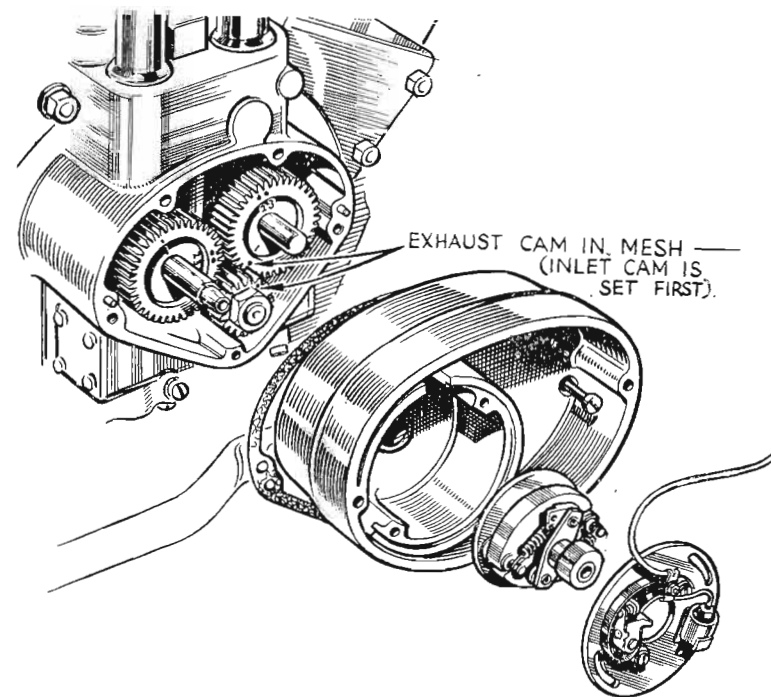

Illustration 17

IGNITION TIMING

To understand the principle, a study of illustration 17 should be made.

The automatic timing control is a taper fit on the shaft for the inlet cam, retained by a central bolt. The cam separating the contact points is rotated by two pegs engaged in the plates for the unit springs.

As the cam is detachable, the position of the cam should be noted, before it is removed. Before setting the ignition timing it is essential to check the contact breaker gap.

CHECK CONTACT BREAKER GAP

(See also Electrical Service.)

Remove two screws securing the cover mounted on the timing case, also the cover. Rotate engine to fully separate contact points.

Check the gap which should be .014—.016".

To adjust the gap release slightly the two inner screws securing the fixed contact plate and adjust the gap as required by moving the pivot plate in the required direction.

REMOVING THE AUTOMATIC TIMING CONTROL

After taking off the cover :

Remove the two screws passing through the slotted holes in the fixed contact breaker plate and remove the plate.

Remove the bolt securing the automatic timing control to the cam wheel shaft.
Fit a 024328 withdrawal bolt in place of the fixing bolt removed which should be lightly tightened. A sharp blow on the end of withdrawal bolt will dislodge the unit from the shaft.
Do not disturb the contact breaker cam.

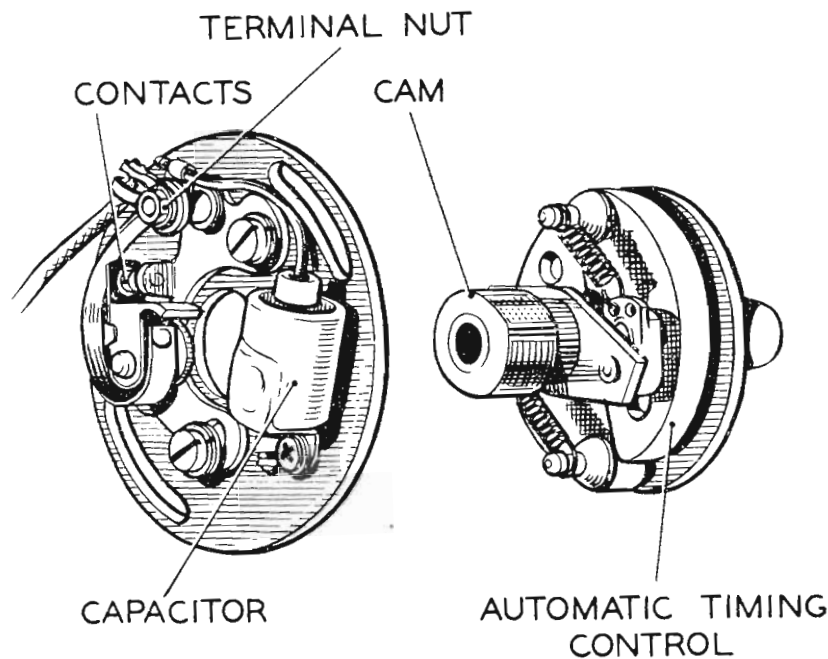

Illustration 18

SETTING THE IGNITION TIMING

The maximum advance is 39° or $\frac{1}{2}$ " (17.7 mm.) before top dead centre, with the automatic timing control wedged open to the **fully advanced position**.

Alternatively the firing point can be set with the piston 19° or $\frac{1}{8}$ " (3.175 mm.) before top dead centre with the automatic timing device in the **fully retarded position**.

To set the timing have available a stiff wheel spoke or similar object $5\frac{1}{2}$ " long.

- Remove H.T. cable and sparking plug.
- Automatic timing control as already described.
- The rocker box side cover.

Turn engine so that both valves are closed (inlet valve opens then closes) then engage top gear.

Insert timing rod through sparking plug hole, feel piston by rocking engine forwards or backwards by turning the rear wheel until it can be felt that the piston is at the extreme top of its stroke with both valves closed.

Refer to illustration 19, and fit automatic advance control, with the gap formed by the two bob weights in line with the two tapped holes, used to secure contact breaker plate. It should be noted that the peak of the cam, or narrowest part, when correctly positioned is approximately at 12 o'clock.

Press the unit firmly onto the shaft that drives it and give the end a sharp tap before re-fitting the fixing bolt. Insert a wood wedge between bob weights to fully separate if fully advanced method is used.

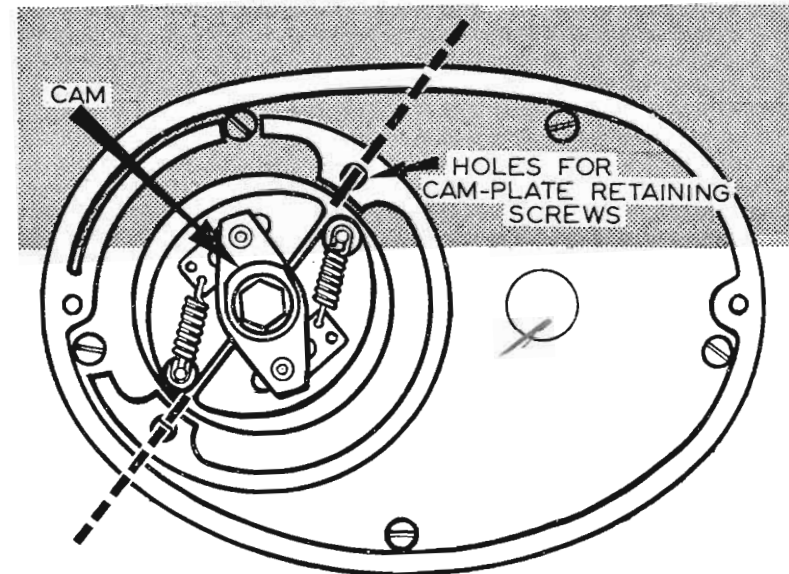

Illustration 19—Setting the ignition timing

Take up the timing rod, check piston position in case the engine has moved. Hold the timing rod as vertically as possible through the sparking plug hole, verify piston is at the top of the stroke. Make a mark on the timing rod flush with the top face of the sparking plug hole, then withdraw the rod.

If the fully advanced method is used make a further mark on the timing rod exactly $\frac{1}{2}$ " ABOVE the previous mark.

If the fully retarded method is used the second mark should be $\frac{1}{8}$ " ABOVE the first one.

Put the timing rod back through the sparking plug hole and by moving the rear wheel turn the engine **BACKWARDS** until the **highest** of the two marks on the timing rod is flush with the top face of the sparking plug hole, dependent on the timing method used.

Fit the contact breaker plate with the capacitor at 3 o'clock, lightly tighten the fixing screws. The exact position of contact point separation is best determined by inserting a strip of cigarette paper between the contact points and moving the plate in a clockwise direction until the paper can be pulled away freely.

If a wedge is used to fully advance the unit, scribe a pencil line on the contact breaker plate and a similar line on the plate housing both lines in register. Remove the contact breaker plate, take away the wedge and re-fit the plate with the two scribed lines in register, and firmly tighten the fixing screws.

As the ignition timing is important, a re-check should be made, before re-fitting the sparking plug, rocker cover, etc.

TO REMOVE AND REPLACE THE OIL PUMP PLUNGER IF AND WHEN NECESSARY ONLY—SINGLES

Remove

Lower end of rocker box oil feed pipe by unscrewing union nut.

Both oil pump end caps.

Oil pump plunger guide screw with pin. (See illustration 4.)

Oil pump plunger, by pushing at front and extracting from rear end of its housing.

Replace by :

Reversing above procedure.

NOTE—Remember there is a paper washer under each oil pump end cap and, when fitting a new paper washer to the front cap, ensure the oil passage in the front cap is not obstructed by the paper washer.

Important

Never attempt to insert the guide screw unless both oil pump end caps are removed, when by moving the pump plunger to and fro with the fingers it can be felt when the pin engages with the groove in the plunger. When correctly fitted the shoulder on the screw will abut against the boss into which it fits. (See illustration 4.)

Do not under any circumstances revolve the engine until quite certain that the pin is correctly positioned otherwise damage will inevitably result.

Securely tighten the screw to prevent any possibility of its unscrewing in use.

Under no circumstances should either the pump plunger or guide screw be disturbed in ordinary routine maintenance.

OVERSIZE PARTS AND REBORING CYLINDER BARREL

Pistons and rings, .020" and .040" larger than standard, are available. These degrees of oversize make it essential for the cylinder barrel to be re-bored to accommodate them.

We can provide that service at prices quoted in the Spares List.

On the 350 c.c. the cylinder standard bore is 2.7187 ± .0005". The 500 c.c. cylinder standard bore is 3.250 ± .0005".

When the wear at the top of the barrel reaches .008" the barrel should be bored out .020" oversize and a new oversize piston and rings fitted.

Crankpin rollers .001" larger than standard can be supplied. We recommend only skilled mechanics should fit these because it is almost general that the big-end journals and sleeves require "lapping" to ensure a correct fit.

REMOVING SPARKING PLUG—ALL MODELS

Always exercise the greatest care to avoid thread seizure when removing a sparking plug. If any resistance is felt, apply penetrating oil. Before replacing plug, it is desirable to coat the thread with "Oil Dag" or Graphite paste. This will guard against seizure upon subsequent removal.

DECARBONISATION—TWINS

TO REMOVE CYLINDER HEADS

To ensure the various parts of each head are not intermixed it is recommended that only one head is removed at a time.

Remove the petrol tank, as already described.

Remove the rocker box covers, as already described.

Remove the sparking plugs.

Remove the exhaust pipes and silencers (no need to separate pipes and silencers) by taking away nuts and washers holding pipes to stays and silencers to rear frame, pulling silencer end of each assembly outwards far enough to allow fixing studs to disengage and then pulling each assembly forwards till disengaged from the cylinder head.

Remove air filter (if fitted).

Remove carburetter by taking away the two fixing bolts and withdrawing to the rear.

Lay carburetter aside.

Remove inlet manifold by taking away the four fixing nuts and washers and withdrawing to the rear. Take care not to damage the gaskets between manifold and heads or rubber ring insert.

Remove cylinder head steady plate (secured by 3 bolts and nuts).

Remove heads by using box spanner 015213 to remove the four nuts that retain each head. After removal invert each head to dislodge the spacers under the nuts and lay aside to await re-assembly.

The cylinder head gaskets will generally adhere to the tops of the barrels but care must be taken not to damage them.

TO REMOVE THE VALVES

Remove rockers. (See illustration 12 for assembly).

Assuming that a valve spring compressor is not available :

Prepare a block of wood about 2" cube, lay same on a bench, place cylinder head over it so that the heads of both valves are supported on the block.

Apply pressure to each valve spring cap, in turn, to sufficiently compress the springs to permit the extraction of the split collet. The collets are a taper fit in the valve spring collar and it may be necessary to give the collars a sharp tap to release them. (A stout screwdriver is a handy tool with which to apply the pressure).

Lift away valve spring collar, springs and spring seat from each valve.

Lift head off the wood block and valves will drop out.

NOTE—The **wide face** on the valve spring seat makes contact with the cylinder head.

TO REMOVE VALVE GUIDES

Apply gentle heat to cylinder head and press upward guide to be removed just sufficiently to permit removal of external circlip. Then thoroughly clean protruding top end of guide re-heat and press downward to extract.

Re-heat when replacing.

REMOVING CARBON DEPOSIT

See details for single cylinder engines Page 34.

VALVE GRINDING

Before commencing valve grinding, carefully examine the face of each valve and, if any are found to be deeply pitted, have them refaced. (Most garages have suitable equipment for that purpose.) Any attempt to remove deep pit marks by grinding will inevitably cause undue and undesirable widening of the seats.

As a rule, inlet valves require very little attention and one light application of fine grinding paste should be sufficient to restore an even matt finish to both valve face and seat. The exhaust valves may require two, or even three, applications but, as already mentioned, excessive grinding is both unnecessary and harmful.

The grinding is accomplished by smearing a thin layer of fine grinding paste (obtainable ready for use at any garage) on the valve face and then, after inserting the valve in the head, partially revolve, forwards and backwards, while applying light finger pressure to the head, raising the valve off its seat and turning to another position after every few movements. (Never revolve the valve continuously in one direction).

The grinding may be considered to be satisfactorily completed when a continuous matt ring is observed on both valve face and seat.

After grinding, all traces of abrasive must be carefully washed off with petrol and a piece of rag, moistened in petrol, should be pulled through the bore of each valve guide to remove any abrasive that may have collected.

NOTE—A piece of oil resisting rubber tube having a bore of $\frac{1}{4}$ " slipped over the valve end will be found a suitable device for revolving the valves during grinding in. This is not included in the standard tool kit. The Part number is 011381.

REMOVING CYLINDER BARRELS AND PISTONS

Unless it is desired to inspect the pistons and rings, during decarbonisation, they are, as already advised, best left undisturbed.

Having removed the cylinder heads **withdraw the cylinder barrels** by :

Lift away the four push rods, identify them for re-fitting and lay aside.

Dealing with one barrel at a time, exert upward pressure on a barrel, slightly rocking to and fro while doing so, and steady the piston with one hand as it emerges from the barrel.

Cover the crankcase throat with clean rag to prevent the entry of foreign matter.

To remove a piston

Using 011188 circlip pliers, contract one of the gudgeon pin circlips and, with a rotary motion, gently withdraw the circlip from its housing. The gudgeon pin may then be pushed out of the piston which action frees the piston from the connecting rod. (Being a parallel, floating fit in the piston and connecting rod small end it is immaterial from which side the gudgeon pin is withdrawn.)

NOTE—It may be necessary to apply a little heat to the piston to permit free gudgeon pin removal and replacement.

Rings may be removed from a piston by peeling off or by introducing behind them three thin and narrow metal strips, equally spaced round the piston, and then sliding them off, taking care not to scratch the piston.

Carefully examine the contact edge of each piston ring and replace any which do not show a bright surface over the whole circumference.

Oversize or undersize parts

The following are the only "oversize" variations provided for the Vertical Twin machines. Big-end and crankshaft centre main bearings:

Undersize010 below normal (Journals to be re-ground to suit).
	.020 " " " " "
	.030 " " " " "

Cylinder re-bore:

.020 in. and .040 in. oversize.

Pistons and rings:

.020 in. and .040 in. oversize.

} See Technical Data for normal size

FITTING PISTONS AND CYLINDER BARRELS

Pistons to be free of carbon on their crowns and all piston ring grooves to be clean.

Piston rings to be clean and on pistons.

Fit a piston to its connecting rod by : Smear gudgeon pin with clean engine oil. Place piston over connecting rod so that the slotted side faces to the front of the machine, introduce gudgeon pin to piston and pass through connecting rod, press right home against the circlip still in situ. Then again, using pliers 011188, contract the other circlip, introduce same into its groove in the piston, using a rotary movement. Make quite certain that the circlip lies snugly in its groove because failure to do so will inevitably lead to serious damage.

(See "NOTE" above).

Before fitting the cylinders, make sure they are clean and examine the base washers and renew same if not perfect.

To fit a new cylinder base washer : first clean off the old washer and all traces of jointing compound. Then smear one side of the new washer with jointing compound and, when that is nearly dry ("tacky") apply to the cylinder.

Place rings on piston, scraper first, then the two compression rings. On all models the top compression ring is chromium plated. These chrome plated rings have a slightly tapered exterior and when new are clearly marked with the word TOP on one side to indicate assembly position. After use this word tends to become indiscernible, but over a large mileage the assembly position can be determined by brightness of the edge contacting cylinder wall. This bright edge is the lower one. When as the result of wear, contact with the cylinder wall appears uniform over the whole width of the ring, it is then immaterial which way round it is refitted.

Space the piston rings so that the gaps are 120° to each other, smear piston and rings and bore of barrel with clean engine oil and, supporting the piston with one hand, gently pass over the barrel, compressing each piston ring with the fingers, as it enters the barrel.

Press the cylinder barrel right down into the throat of the crankcase.

Fit the second piston, gudgeon pin, rings and barrel in a like manner.

Revolve the engine till the pistons are at the top of their strokes and then, with a clean rag, wipe off all surplus oil. All is now ready to re-fit the cylinder heads.

TO RE-FIT THE CYLINDER HEADS

Clean the valve stems and the bores of the valve guides with rag moistened with petrol, make sure all other parts are clean, then smear each valve stem with clean engine oil and proceed to re-fit the valve stems by reversing the procedure taken to dismantle them.

Insert the four valve push rods into their original positions and, after making sure that the cylinder head gaskets are undamaged and in position, proceed to fit the two heads and leave the two sets of four cylinder head retaining nuts finger tight.

Now re-fit the inlet manifold, making sure the two paper gaskets are undamaged, and leave the four retaining nuts only just tight enough to ensure correct alignment.

Next, fully tighten down the four retaining nuts on each head, treating each, diagonally, bit by bit, till all are fully down.

Then, fully tighten the inlet manifold retaining nuts and re-fit the carburetter

Next, carefully check each rocker clearance, as previously described, and re-set if necessary. (The correct rocker clearance with cold engine is .006" for inlet and exhaust.)

The gaskets under each rocker cover should be inspected and, if not sound should be replaced after which the rocker covers can be refitted.

Next re-fit the cylinder head steady plate and securely tighten the three fixing bolts.

NOTE—Before re-fitting carburetter make sure the rubber ring in manifold joint face is in position and undamaged.

TO RE-TIME THE IGNITION—TWIN

Before proceeding to time the ignition it is advisable first to check the contact breaker point gap, which should be from .010" to .012" and correct it if necessary.

Having loosened the nut securing the magneto driving pinion, release same from the tapered end of the magneto shaft by means of a special extractor, as described on page 00.

Remove the inlet rocker cover from the off-side cylinder head.

Remove the sparking plug from the off-side cylinder.

Insert a small rod into the sparking plug hole and, feeling the piston with the end of this rod, carefully turn the engine in its normal direction of rotation until the piston is exactly at the top of the stroke after the inlet valve has closed.

Hold the rod as vertical as the angular sparking plug hole will permit, make a mark on same exactly coinciding with the top edge of the sparking plug hole boss. Then withdraw the rod and make another mark exactly $\frac{3}{8}$ " higher up. Re-insert the rod and turn the engine backward until the higher mark coincides with the top edge of the sparking plug hole boss.

Place the ignition control lever in the fully advanced position.

Next, taking care not to disturb the piston position, turn the magneto in a clockwise direction (looking at the contact breaker end of the magneto) until the contact breaker points are just about to separate by reason of the fibre block on the bell crank lever commencing to mount the lower cam hump.

The exact point of separation is best found by inserting between the contact points a strip of thin tissue paper when the separation point can be determined by the paper just being released with a light pull.

Having obtained this position, press the magneto driving gear on to its taper with the fingers and lightly tighten the securing nut.

It is next advisable to re-check the setting by again turning the engine to the position at which the piston is $\frac{3}{8}$ " before the top of the firing stroke, re-inserting tissue paper between the contact points and confirming that same can be released with a light pull.

Upon being satisfied that the setting is correct securely tighten down the nut fixing the magneto driving gear.

Thoroughly clean off all traces of jointing compound from face edges of the timing cover and crankcase and then smear both faces with new jointing compound, which leave till tacky and then re-fit the cover to the crankcase. ("Wellseal" recommended.)

The whole operation of timing the ignition will be found quite simple if the foregoing instructions are carefully followed.

NOTE—The sparking plug high tension cable for the off-side cylinder is that connected to the rear pick-up on the magneto.

VALVE TIMING—TWIN

Inlet valve opens	24° before top dead centre
Inlet valve closes	65° after bottom dead centre
Exhaust valve opens	63° before bottom dead centre
Exhaust valve closes	25° after top dead centre

(Check valve timing with .012" rocker clearance.)

Upon removing the timing gear cover (secured by 10 screws and 1 nut) and the pump plate assembly it will be observed the valve timing gears are marked to facilitate correct assembly.

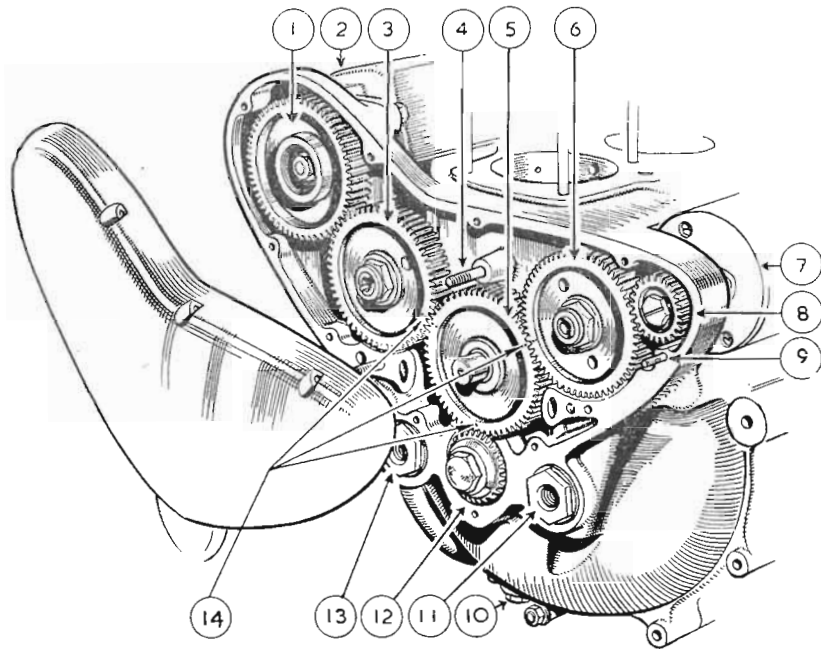

Illustration 20

Valve timing gear

See page 95 for particulars of special timing disc graduated in degrees.

- | | |
|--|---|
| 1 GEAR WHEEL ON MAGNETO ARMATURE SHAFT. | 9 STUD, IN DYNAMO BODY AND PASSING THROUGH CRANKCASE AND TIMING GEAR COVER. |
| 2 MAGNETO. | 10 CRANKCASE DRAIN PLUG. |
| 3 GEAR WHEEL ON INLET CAMSHAFT. | 11 ADAPTOR TO ACCOMMODATE OIL FEED PIPE BANJO PIN. |
| 4 ONE OF THE THREE STUDS RETAINING THE OIL PUMPS ASSEMBLY. | 12 TIMING PINION ON CRANKSHAFT. |
| 5 INTERMEDIATE (OR IDLE) GEAR. | 13 ADAPTOR TO ACCOMMODATE OIL RETURN PIPE BANJO PIN. |
| 6 GEAR WHEEL ON EXHAUST CAMSHAFT. | 14 MARKS TO SET TIMING. |
| 7 DYNAMO. | |
| 8 GEAR WHEEL ON DYNAMO ARMATURE SHAFT. | |

One tooth gap of the mainshaft small pinion is marked with one centre punch dot and a tooth of the idle pinion, into which it meshes, is similarly marked. With these two marks coinciding it will be seen that a tooth on each side of the intermediate pinion is marked with two centre punch dots which also coincide with a similarly marked tooth gap on each of the camshaft driving gear wheels.

During assembly it is only necessary to mesh the gears with these various marks coinciding to ensure correct valve timing.

The dynamo and magneto drive pinions are not marked. The dynamo does not need "timing" and if, for any reason, the magneto timing has been disturbed, it is re-set as described later.

Removal of gears

When completely dismantling the engine there is no necessity to remove the small timing pinion from the crankshaft before splitting the crankcase because the complete crankshaft can be taken away with the pinion still in position.

If, however, it is desired to remove the pinion without completely dismantling the engine a special extractor is required (part number 015273). This consists of a nut, threaded externally and internally. The external threads enable it to be screwed into the threaded centre of the pinion and the internal threads accommodate a specially designed and hardened bolt which, upon screwing down, pulls off the pinion. This same tool is used for the removal of the magneto gear.

The intermediate gear needs no extractor.

The gears on the two camshafts (secured by nuts having left-hand threads) have to be mechanically withdrawn and each has two holes drilled and threaded to accommodate the two bolts of a bridge type extractor (part number 015374) which has a central bolt threaded in the bridge. The two outside bolts are screwed into the holes in the gears whereupon application of the centre bolt being screwed into the bridge bears on the end of the shaft thereby causing the gear to be withdrawn.

The gear on the dynamo needs no extractor because the dynamo, complete with gear assembled, is easily and quickly removed from the engine and the subsequent removal of the gear from the dynamo shaft is a simple workshop operation.

CARBURETTER SERVICE

The information given in this section includes all that will normally be required by the average rider. For further details, particularly those connected with racing and the use of special fuels, we refer the enquirer to the manufacturers of the carburetter, **Amal Ltd., Holford Road, Witton, Birmingham, 6.**

Our **Spare Parts Department** does not stock every part of the carburetter but confines its stock to those parts that, from time to time, may be required. Those parts include floats and float needles, jet taper needles, pilot jets, main jets, needle jets and washers.

CARBURETTER FUNCTION

The petrol level is maintained by a float and needle valve and, in no circumstances, should any alteration be made to these parts. In the event of a leaky float, or a worn needle valve, the part should be replaced with new. (Do not attempt to grind a needle to its seat.)

The petrol supply to the engine is controlled, firstly, by the main jet and, secondly, by means of a taper needle (see illustration 21) which is attached to the throttle valve and operates in a tubular extension of the main jet.

The main jet controls the mixture from three-quarters to full throttle, the adjustable taper needle from three-quarters down to one-quarter throttle, the cut-away portion of the intake side of the throttle valve from one-quarter down to about one-eighth throttle, and a pilot jet, having an independently adjusted air supply, takes care of the idling from one-eighth throttle down to the almost closed position. These various stages of control must be kept in mind when any adjustment is contemplated. (See illustration 21, for location of the pilot jet air adjustment screw). The pilot jet unlike on earlier models, is now detachable for cleaning.

The size of the main jet should not be altered save for some very good reason. See "DATA" for details of standard sizes of jet, throttle valve, and jet taper needle.

With the standard setting it is possible to use nearly full air in all conditions, except, perhaps, when the engine is pulling hard up hill or is on full throttle, when some benefit may be obtained by slightly closing the air control.

Weak mixture is always indicated by popping, or spitting, at the air intake.

A rich mixture usually causes bumpy, or jerky, running and, in cases of extreme richness, is accompanied by the emission of black smoke from the exhaust.

CARBURETTER ADJUSTMENT

With the taper needle projection, main jet size, and type of throttle slide specified (see page 6) correct carburation except at idling speed is assured.

In the event of difficulty being experienced look for cause under heading Useful Information (pages 87 and 88).

To check for correct idling mixture, first run the engine until it is just warm but not hot when with the throttle nearly closed and air fully open it should fire evenly and slowly. If it fails to do so, first of all make certain that the sparking plug is clean and the point setting correct. Having done this and idling is still uneven try re-setting the pilot jet air screw.

Adjustment of this air screw is not unduly sensitive and it should be possible to obtain the correct setting for even firing in a few seconds.

In the event of even firing at idling speed being unobtainable by adjustment of the air screw look for obstruction in the pilot jet.

Having obtained even firing all that remains is to adjust if necessary the position of the throttle stop screw until the desired idling speed is obtained.

TWIST GRIP ADJUSTMENT

A screw is provided in one of the halves of the twist grip body to regulate the spring tension on the grip rotating sleeve. This screw must be screwed into the body to increase the tension.

The most desirable state of adjustment is that when the grip is quite free and easy to operate but, at the same time, will stay in the position in which it is placed.

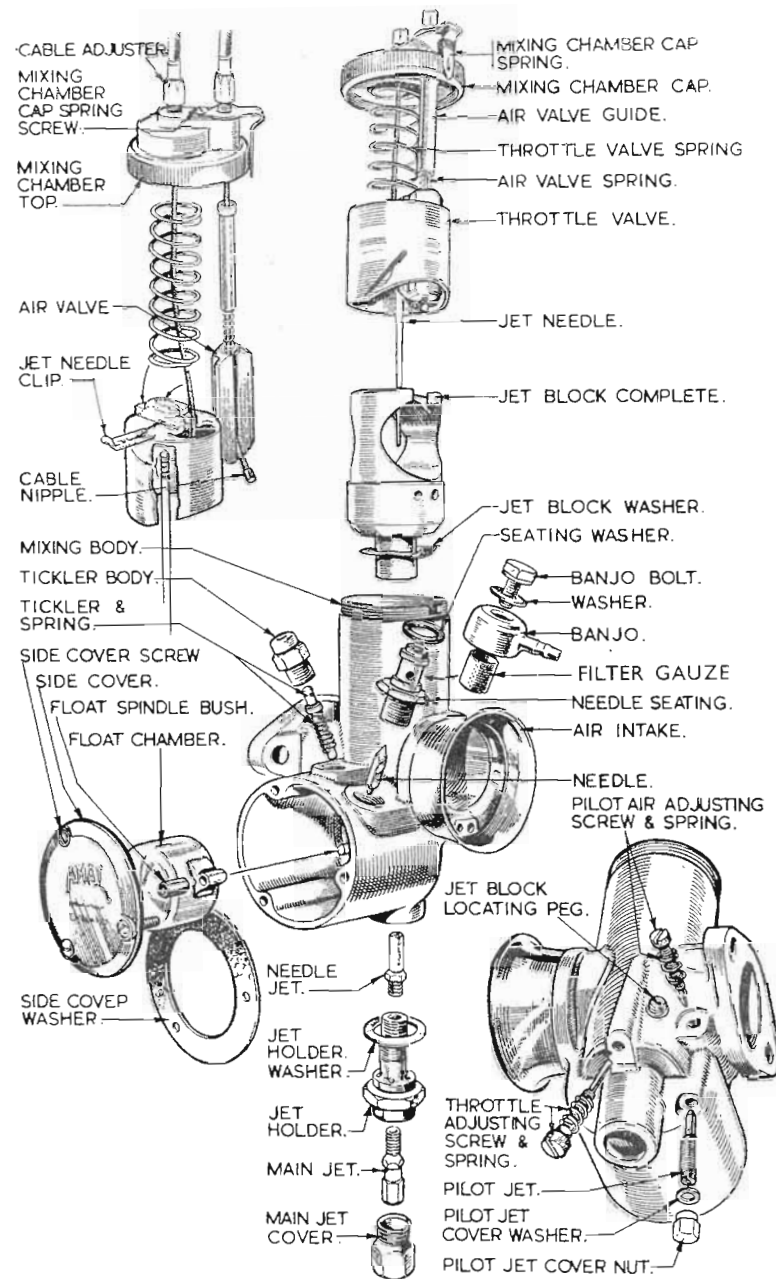

Illustration 21

Carburetter details in assembly order

TWIST GRIP ADJUSTMENT CONT.

The complete twist grip can be moved on the handlebar by slackening the two screws that clamp together the two halves of the body. The most desirable position is that in which the throttle cable makes the cleanest and most straight path to the under-side of the petrol tank.

AIR FILTER

In locations, such as the United Kingdom, where the roads and atmosphere are particularly free from dust, it is not considered necessary to have an air filter fitted to the carburetter, but in countries where the atmosphere contains a very heavy dust content, an air filter is essential in order to prevent abrasive wear.

The filter available (optional extra) for the conditions mentioned above is of the "Oil Wetted" type, and this requires periodical servicing.

When servicing the air filter, withdraw the filter element. Thoroughly wash this in petrol, paraffin or other suitable solvent and allow to dry. Then re-oil, using one of the light oils (SAE-20), enumerated in the final table on page 13, and allow to drain before replacing in the filter case. Clean at intervals of 2,500 to 5,000 miles according to road conditions, and renew the element every 10,000 miles.

TO REMOVE THE AIR FILTER ELEMENT

Pull the rubber hose off the carburetter air intake.

Remove the frame cover and pull off the hose end from the air filter.

Remove the bolts securing the filter to the oil tank and frame, withdraw the entire filter unit.

The filter element is held in its cage by bolts and nuts and lock washers. After cleaning replace the filter. When the hose is replaced on the filter make sure that it is properly located.

CARBURETTER TUNING INFORMATION

Poor idling may be due to :

Air leaks. Either at junction of carburetter and inlet manifold, or by reason of badly worn inlet valve stems or guides.

Faulty engine valve seatings.

Sparking plug faulty, or its points set too closely.

Ignition advanced too much.

Contact breaker points dirty, pitted, loose, or set too closely.

High-tension wire defective.

Pilot jet not operating correctly. Partially choked or incorrect air supply.

Rockers adjusted too closely.

Heavy petrol consumption may be due to :

Late ignition setting.

Bad air leaks. Probably at carburetter or manifold joints.

Weakened valve springs.

Leaky float. (Causing flooding.)

Taper needle extension insufficient.

Poor compression, due to worn piston rings or defective valve seatings. (Test compression with throttle wide open.)

TRANSMISSION SERVICE

THE GEAR BOX

The gear box provides four speeds and has a positive foot change, operated by the right foot and a kick-starter.

It is retained to the frame by being clamped between the two engine rear plates by two bolts. The bottom fixing bolt acts as a pivot. The top fixing bolt passes through the gear box top lug and the rear plates, which are slotted, thereby allowing a swinging fore and aft movement of the gear box to enable the front driving chain to be adjusted. That movement is controlled by an adjusting bolt (marked 1 in illustration 27) secured in an eye bolt (marked 2 in illustration 27) and locked in the required position by a nut (marked 3 in illustration 27).

Illustration 22 clearly shows the general internal gearbox layout, the simple gear selection and kick-starter mechanism.

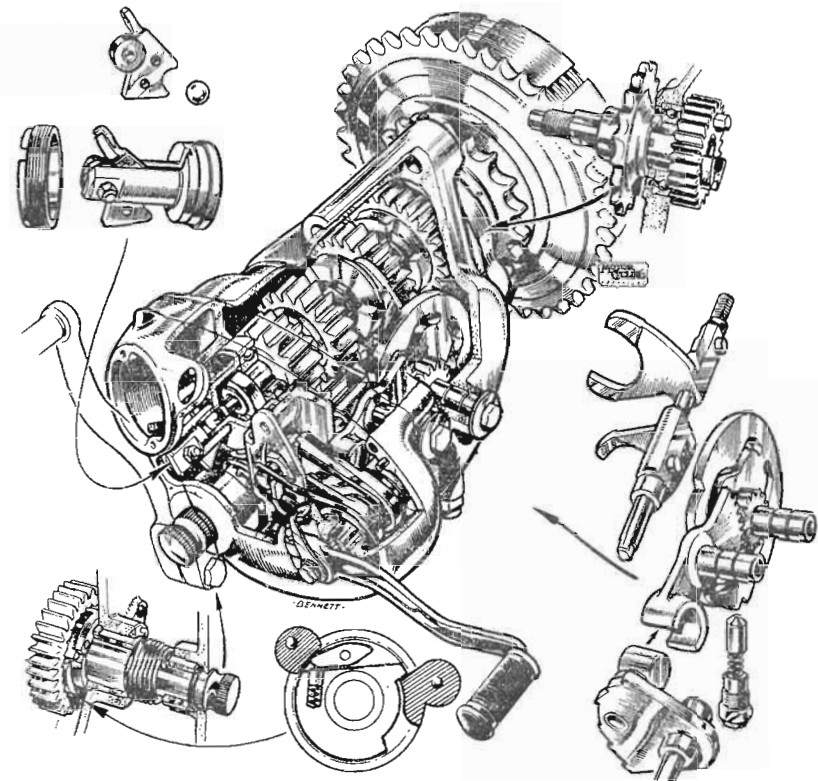

Section through gearbox showing gears and clutch with actuating mechanism

Illustration 22

FOOT CHANGE OPERATION

Gears are selected by raising and depressing the gear change pedal which is attached to the pawl carrier, the operating pawl, is spring loaded by a hairpin type spring.

The gear change pedal, which is also spring loaded by a similar type spring returns the pedal to the central position, after a gear has been selected, upon foot pressure being released. An upward movement of the pedal engages first gear, a downward movement causes engagement of higher gears.

Only a light, but deliberate pressure on the pedal is necessary, a jabbing or stamping action on the pedal will result in damage to the operating mechanism.

When the gear pedal is moved the spring loaded pawl engages with the ratchet plate, connected to the quadrant, by means of a large steel roller. Teeth on the quadrant engage with teeth on the cam plate spindle, rotating cam plate in the direction desired.

The selector forks on a spindle are engaged in a profiled groove machined in the cam plate causing the gears to shift, when cam plate is rotated.

The outer periphery of the cam plate, has notches machined in it, which engage with a spring loaded plunger, thus positively indexing the gears when selected.

An indicator plate is mounted on the end of the quadrant spindle, to enable the gear selected or neutral position to be identified.

TO REMOVE GEAR BOX OUTER COVER

Remove oil drain plug and drain off oil contents of the gear box.

Take off filler cap plate, disconnect clutch cable inner wire from operating lever, unscrew cable adjuster and take out the cable.

Remove kick-starter crank, by releasing pinch bolt.

Remove foot change indicator plate by unscrewing bolt in foot change ratchet plate spindle, leave the foot change pedal in position.

Remove five cheese headed screws securing outer cover.

The gear change pedal can be used to pull gently away the outer cover with care, to avoid damage to the paper gasket. Should this gasket partly adhere to the outer and inner cover during this process, separate the washer from the outer cover with the aid of a penknife or similar tool.

TO REPLACE GEAR BOX OUTER COVER

Ensure paper gasket is undamaged, before fitting cover. If foot change pawl spring is removed, or displaced, it must be re-fitted correctly as this spring is not reversible. It will be observed that one leg on this spring is straight, the other is cranked.

Correct location is with the straight leg of the spring in the uppermost position.

Place the spring legs on each edge of rocking pawl (see illustration 23), offer up cover and replace parts in reverse order described for removal.

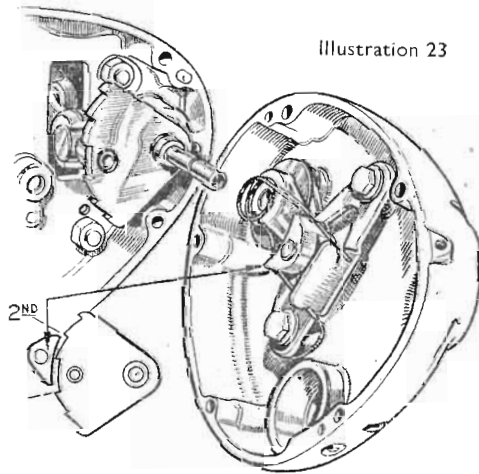

Illustration 23

TO REMOVE GEAR BOX INNER COVER

Remove ratchet plate, with its spindle.

Remove clutch actuating arm and roller

Remove lock ring securing clutch operating body, the body can be taken out—watch for $\frac{1}{2}$ " steel ball.

Remove mainshaft nut, exposed when clutch operating body is removed.

Remove seven nuts securing inner cover to gear box shell.

The cover can now be removed with kick-starter axle in position, by gently tapping behind the front end of the cover with care, to avoid damage to the paper gasket.

TO REPLACE GEAR BOX INNER COVER

Ensure gasket is undamaged. Fit inner cover, firmly secure seven fixing nuts. Fit mainshaft nut, clutch operating body and steel ball, also clutch actuating arm and roller.

NOTE—Before finally tightening lock securing operating body, position small clutch operating lever to register with centre of aperture for clutch cable adjuster.

Fit ratchet plate and spindle.

FRONT CHAINCASE COVER—SINGLES

WARNING—The stator for the A.C. generator is bolted to the outer cover of the front chain case. Attached to the stator is a cable, which passes through the rear portion of the chain case. Therefore take away the outer cover with extreme care to avoid a strain on the cable. (See illustration 24).

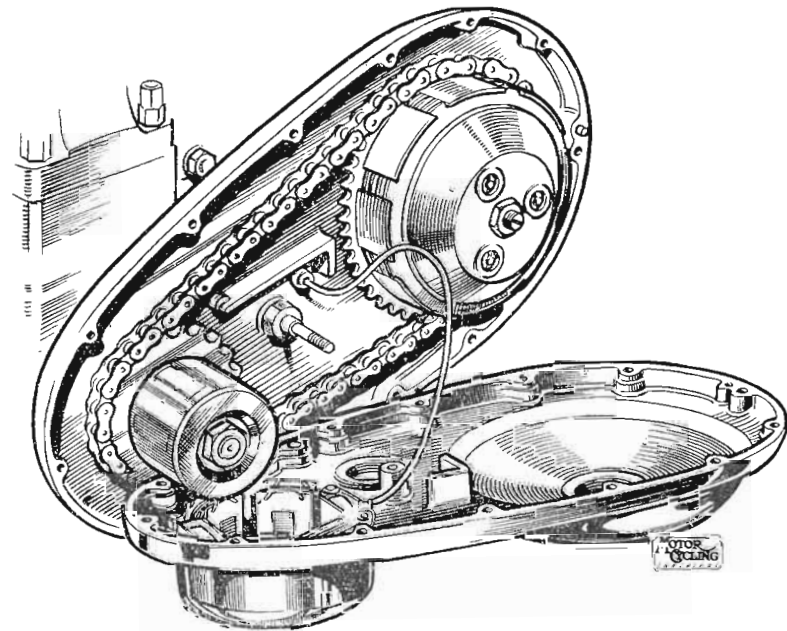

Illustration 24

TO REMOVE OUTER CHAINCASE COVER

Remove the rear engine plate cover and disconnect three snap connectors.

Take off the left side footrest.

Unscrew adjusting nut on rear brake rod.

Place a tray under chaincase to catch oil.

Remove drain plug, allow time to drain (content 12 ozs.).

Remove screwed inspection cap (use spanner 018178 in slot).

Remove nut in centre of chaincase.

Remove fixing screws (14).

Depress the rear brake pedal and carefully remove outer cover squarely to avoid damage to the stator windings, and thread each connector through the rubber grummet in the chaincase one at a time. (See illustration 24).

TO REMOVE CHAINCASE COVER—TWINS

Remove left side exhaust pipe with silencer attached.
Remove left side footrest.
Remove adjusting nut on rear brake rod.
Place a tray under chaincase to catch oil.
Remove screwed inspection cap (use spanner 018178 in slot).
Remove drain plug, allow time to drain (content 8 ozs.).
Remove nut in centre of chaincase.
Remove fixing screws (14).
Depress brake pedal and take away the cover.

TO REMOVE CLUTCH AND FRONT CHAIN—ALL MODELS

Take off the chaincase cover as previously described.
Unscrew clutch spring adjusting nuts.
Remove clutch pressure plate, with springs and spring cups.
Engage top gear, re-fit brake rod, apply pressure on rear brake pedal, unscrew nut on mainshaft securing clutch hub.
Remove chain connecting link, take away the chain, detach clutch assembly as a unit from mainshaft.

Fit clutch assembly by :

Fitting clutch hub to gear box mainshaft, also shaft nut and spring washer.
Engage top gear, apply rear brake and fully tighten gear box shaft nut.
Apply a little anti-centrifuge grease on clutch rollers.
Fit clutch sprocket and complete clutch assembly.
See paragraph Clutch Spring Adjustment.

TO REPLACE FRONT CHAINCASE COVER—SINGLES

Ensure paper gasket for joint is undamaged.
Offer up chaincase into position and gently take up the cable slack by pulling lightly the cable from the rear of the chaincase.
Locate the cover with the central fixing nut and lightly tighten.
Fit the fixing screws and tighten them first diagonally, then all round the case. Tighten the central fixing nut, fill case with fresh oil to just below the inspection cap orifice.
Replace screwed inspection cap and other parts in reverse order.

TO REPLACE FRONT CHAINCASE COVER—TWINS

Follow instructions for single cylinder models omitting the cable details.

TO REMOVE A.C. ROTOR AND ENGINE SPROCKET—SINGLES

The rotor is keyed on to the engine shaft, the sprocket is splined.
Remove chaincase cover.
Engage top gear and reconnect rear brake rod to pedal.
Apply pressure on rear brake pedal and unscrew the locknut and nut securing rotor to engine shaft.
Remove the washer and pull off the rotor.
Remove connecting link from front chain.
Remove key for rotor and distance piece ($\frac{1}{2}$ " wide).
Remove engine sprocket.
NOTE—The distance piece behind engine sprocket can be left in position.

TO REPLACE ROTOR AND ENGINE SPROCKET—SINGLES

Re-fit parts in reverse order given for dismantling.
When re-fitting chain connecting link, ensure spring clip is fitted so that the **closed end faces the direction of rotation**.
Check chain adjustment before re-fitting chaincase cover.

TO REMOVE ENGINE SPROCKET—TWINS

Follow dismantling instructions for Single Cylinder Models.
Straighten lock washer on engine shaft.
Unscrew release valve body with spanner on the larger of the two hexagons, disconnect front chain and pull off engine sprocket.
Note instructions for fitting the spring clip when chain is replaced.
Re-assemble in reverse order used for dismantling.

CLUTCH OPERATING MECHANISM ADJUSTMENT

Correct adjustment of the clutch operating mechanism is of the utmost importance and the following instructions must be carefully observed.

In order to understand the method of clutch withdrawal a study of illustrations should be made.

To enable the clutch to function satisfactorily $\frac{1}{8}$ " to $\frac{3}{16}$ " free movement of the operating cable is essential. This is checked by lifting the outer casing of the clutch cable at the position where it enters the screwed adjuster on the kick-starter case cover. If the adjustment is correct it should be possible to freely move the casing up and down with the fingers $\frac{1}{8}$ " to $\frac{3}{16}$ ".

If the free movement is excessive causing clutch drag or noisy gear changing, adjustment should be made as follows.

Release the clutch cable adjuster lock nut and then screw in the adjuster as far as it will go to ensure that the operating lever A (illustration 25) is in its normal position.

Now turn to the opposite side of the cycle and remove the screwed cap on the chaincase cover.

Then using the sparking plug box key supplied in tool kit, loosen lock nut B.

Then with a screw driver gently screw in the thrust cup C until contact with the thrust rod can be felt after which unscrew exactly one half turn and then securely re-tighten the lock nut B taking care to observe that the screwed thrust cup does not also turn while doing so.

Replace the screwed cap and then make the final adjustment by unscrewing the cable adjuster until the recommended free movement of the casing is obtained after which re-tighten the cable adjuster lock nut.

As a result of wear of the clutch friction plate inserts after prolonged use, the plates tend to close up towards each other. This will have the effect of reducing the free movement in the operating mechanism referred to above.

Clutch slip resulting from lack of free movement will rapidly ruin the inserts and may generate sufficient heat to soften the clutch springs. Therefore should clutch slip develop an immediate check of free movement must be made.

In this case after slacking off the cable adjuster, unscrew the cup C a turn or two and then gently screw in until contact with the thrust rod is felt after which as already detailed it should be unscrewed exactly one half turn before re-tightening the lock nut B. Lastly adjust the cable for the specified free movement.

To remove a clutch control cable

Remove the oil filler cap from the kick-starter case cover.
Screw right home the clutch cable adjuster that is located in the top of the kick-starter case cover.
Disengage, from the operating lever, the clutch cable inner wire by operating through the oil filler cap opening.
Completely unscrew the clutch cable adjuster.
Disengage, from the handlebar operating control lever, the clutch inner wire.
Pull cable, by its lower end, till removed from the machine, easing it through the frame cable clips while doing so.

To replace a clutch control cable

Reverse the above instructions and, finally, adjust as detailed earlier.

CLUTCH SPRING ADJUSTMENT

In the event of clutch slip and the operating mechanism has been adjusted correctly the clutch spring adjusting nuts and cups may require attention. Remove the chaincase cover to expose clutch assembly.

Remove the clutch spring adjusting screws, take out the springs and cups then verify the clutch spring cups are not in contact with the holes machined in the steel plate for the clutch shock absorber assembly (see illustration 26).

If there is evidence of contact by a burr formed on the cup remove the burr with a fine file and apply a little graphite grease on the cup before replacing.

Check the clutch springs for free length ($1\frac{7}{8}$ " normal).

Replace springs if free length is $\frac{3}{16}$ " to $\frac{1}{4}$ " below normal.

After re-fitting spring cups and springs screw in adjusting screws until the heads of the screws are flush with the spring cups.

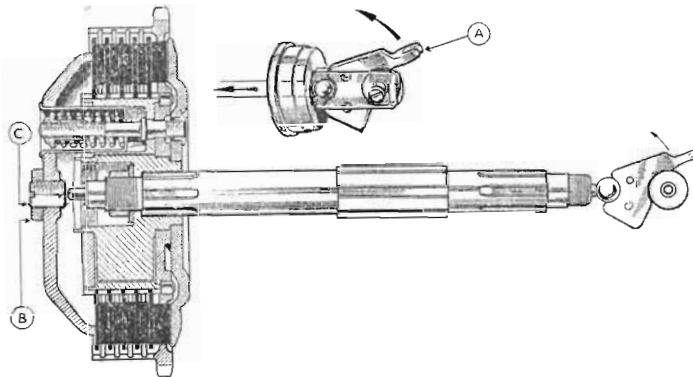

Illustration 25

Clutch, gear box main shaft and clutch operating mechanism

TO DISMANTLE CLUTCH SHOCK ABSORBER

The six rubber blocks used in the shock absorber can be replaced by:

Removing front chaincase.

Removing clutch spring pressure plate together with spring and spring cups.

Removing three screws also plate for shock absorber compartment (see illustration 26).

A "C" shaped spanner engaged with two slots in the clutch hub or a clutch steel plate with an extension handle welded to it can be used to compress the thick rubbers, whilst the thin rubbers are extracted.

To do this engage top gear, apply pressure on the rear brake pedal, position the tool to be used and pull the handle upwards, or opposite to the direction of clutch rotation. With the aid of a short piece of wheel spoke with a pointed end the thin rubbers can be first prised out then the thick ones.

Reverse this procedure to refit replacement rubber blocks.

NOTE—If clutch hub is removed, a tool similar to a gear box mainshaft held in a vice will be required to hold the hub, whilst rubber blocks are extracted.

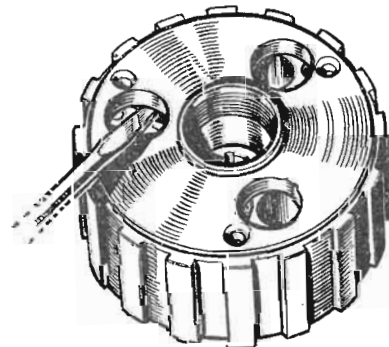

Illustration 26

TO REMOVE CLUTCH BEARING

The clutch hub is secured to the clutch back plate by the three clutch studs, with lock nuts. The bearing can be removed after separating the clutch hub from the back plate. Apply a little anti-centrifuge grease on bearing before final assembly.

TO DISMANTLE GEAR BOX

Dismantle outer and inner covers as described.

If the gear box mainshaft is to be taken out the clutch complete must be removed from the mainshaft.

Remove low gear pinion on layshaft (kick-starter wheel).

Remove striker fork spindle, by unscrewing, using spanner on the two flats machined at the outer end.

Remove mainshaft, with the gears on it after disengaging striker fork from cam plate. The layshaft can now be taken out, with gears on it, after disengaging layshaft striker fork from cam plate.

If layshaft does not come out easily, rock layshaft up and down whilst pulling on the end of the shaft, to extract it from the ball race.

Remove screw securing lock plate to rear chain sprocket.

Remove chain sprocket nut, which has a LEFT HAND THREAD.

Remove chain sprocket and distance piece from sleeve gear, mounted on splines.

Remove sleeve gear, by withdrawing through its ball bearing.

To remove oil seal without damage, the gear box case must be gently heated and dropped face joint downwards on to a bench or wood block, the main ball race and oil seal will then fall out of position, together with the layshaft ball bearing.

If oil seal is to be exchanged only, the used seal can be prised out; then gently press replacement into position.

If this part of dismantling is to be carried out with gear box in frame, remove the chain sprocket nut before removing outer gear box cover. Top gear can then be engaged, with rear chain in position so that pressure can be maintained on the rear brake pedal, to facilitate removal of chain sprocket nut.

Alternatively, obtain assistance to hold the rear wheel from turning whilst sprocket nut is released.

REMOVAL OF CAM PLATE

Remove hexagonal dome nut, on front end of gear box, take out spring and plunger.

Remove small hexagon bolt, on front of gear box immediately above the plunger aperture, cam plate can now be removed.

Remove remaining small bolt on front end of gear box, take out quadrant, with its spindle.

NOTE—This spindle is not detachable.

REFITTING CAM PLATE

Place the quadrant in position, secure, with its bolt and washer. Raise the lever on the quadrant until the top radius on the lever is in line with the top right hand stud for gear box inner cover (top gear position).

Fit cam plate and verify the first two teeth only on quadrant are visible through groove in cam plate for correct location.

Secure cam plate with its bolt and washer.

Refit plunger, spring cap nut.

NOTE—Steel roller must be fitted to quadrant before inner cover is replaced.

FITTING GEARS INTO GEAR BOX

Gently warm gear box case.

Fit main gear wheel bearing, layshaft bearing and oil seal.

Fit sleeve gear in bearing, sprocket distance piece, sprocket, securing nut LEFT HAND THREAD, lock washer and retaining screw.

Fit mainshaft with third and second gear assembled, also striker fork in third gear.

Fit striker fork spigot into groove in cam plate.
 Fit layshaft, with small gear, third gear, also second gear with striker fork in second gear.
 Fit striker fork spigot into groove in cam plate.
 Fit striker fork spindle, after lining up both forks.
 NOTE—Moving the cam plate, will assist in lining up striker.
 Fit low gear pinion on mainshaft.

DISMANTLING KICK STARTER ASSEMBLY

Remove outer and inner cover for gear box.
 Using a stiff piece of wire with one end shaped like a button hook, pull out from the inner cover, the turned in end of the kick-starter return spring.
 Lift out opposite end of this spring from hole drilled in the kick-starter axle, take away spring, the axle can then be pressed out of the cover.
 The kick-starter, pawl, plunger and spring can now be removed for examination, or renewal.

TO REPLACE KICK STARTER ASSEMBLY

Fit kick-starter axle, with pawl assembled in cover, turn the axle so that the hole in it for the return spring is at 12 o'clock.
 Fit return spring on the axle, insert the end of the spring which is turned down vertically into hole drilled in axle. Using tool recommended for spring removal, hooked in opposite end of spring, pull the spring sufficiently to enable the turned in end to enter hole drilled in the cover.
 Replace inner and outer cover as detailed previously.

To replace a clutch control cable

Reverse the above instructions and, finally, adjust as detailed earlier.

FRONT CHAIN ADJUSTMENT

Refer to illustration 27.
 Remove engine plate cover.
 Slacken the nut of bolt (5).
 Slacken the nut (3).
 Screw the bolt (1) into the crosshead (2) to take up slack in the chain.
 Pull on the rear chain to move the gear box and tighten the front chain.
 Remove the inspection cap from the chain-case and check tension by applying upward pressure to the chain.
 The correct amount of whip is $\frac{3}{8}$ ".
 Check the adjustment in several positions and adjust for the tightest point.
 When the correct adjustment has been obtained, tighten nuts (3) and (5), and replace cover.
 If the chain is tight, screw the bolt (1) out of the crosshead (2).
 After making adjustments to the front chain always check the adjustment of the rear chain.
 Slacken or tighten as necessary.

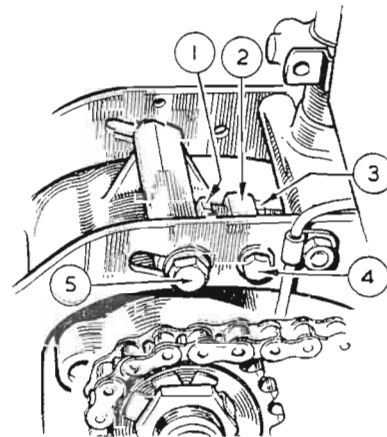

Illustration 27

Front chain adjustment

- 1 ADJUSTING BOLT.
- 3 ADJUSTING BOLT LOCK NUT.
- 5 ENGINE PLATE BOLT.

REAR CHAIN ADJUSTMENT

To obtain rear chain adjustment the rear wheel is bodily moved in the rear frame fork ends, which are slotted for the purpose. Adjusting screws with lock nuts are provided on the forward side of each slotted end.

To adjust the chain place cycle on the stand and slightly slacken the spindle end nut and also slightly slacken the brake drum dummy spindle lock nut the hexagon of which is adjacent to the spindle end nut. Then slacken back the adjuster screw lock nut on each side and unscrew each adjuster bolt in turn to exactly the same extent until the correct chain tension is obtained. While on the stand the chain whip should be $1\frac{1}{8}$ " (see note below). Then fully re-tighten spindle nuts and also the adjuster screw lock nuts. Chain whip must always be checked midway between the two sprockets and the rear wheel should always be turned to obtain the position of least slackness. This is because chains rarely wear evenly and there is usually one position at which the chain is tighter than at any other. It is at this position that the adjustment check should be made.

NOTE—The chain adjustment specified while cycle is on the stand is reduced to $\frac{1}{2}$ " when the wheel is on the ground and the rider seated. This is due to chain sprocket centres varying slightly as the result of movement of the rear swinging arm.

NOTES ON REAR CHAIN ADJUSTMENT

Before tightening the rear chain always first check front chain adjustment and if attention is necessary adjust the front chain first. This is because adjustment of the front chain disturbs that of the rear chain.

Therefore after making adjustment to the tension of the front chain always afterwards check that of the rear chain.

It should also be noted that adjusting the rear chain will disturb rear brake adjustment which should therefore always be checked subsequently.

REMOVING AND REFITTING REAR CHAIN

To protect the rear chain from mud and water it is very closely shrouded by the chain guard and removing the chain without first detaching the chain guard can present considerable difficulty. A simple procedure however is as follows.

First obtain a piece of thin string about ten feet long.

With cycle on the stand turn the rear wheel until the chain connecting link is at a position near the rear sprocket and remove the connecting link.

Now pass the string through the centre hole of the end link of the top run, draw the two ends of the string level and tie together.

Then pull the bottom run of the chain backwards with one hand while keeping the string taut at the rear end with the other hand.

As the end of the top run of the chain disengages with the gear box sprocket it will leave the string attached lying one strand each side of the sprocket teeth.

When the chain is well clear cut the string on one side only at a point about one foot from where it is looped through the chain link.

Leave the string then in situ awaiting chain re-fitting.

To re-fit the chain

Pass the longer cut end of the string through the centre hole of the end chain link and then tie the two loose ends of the string together.

Then pull the string from the rear end at the same time guiding the chain up to engage with the gear box sprocket.

Continue pulling until the chain encircles the rear wheel sprocket when remove the string and refit the connecting link taking care while doing so to attach the spring clip with its closed end facing the direction of rotation.

FORK & FRAME SERVICE

STEERING HEAD ADJUSTMENT

The steering head frame races are of the floating self-aligning type and have spherical seats. Therefore they do not fit tightly in the head lug.

Occasionally test the steering head for correct adjustment by exerting pressure upwards from the extreme ends of the handlebars.

It is particularly important that the adjustment is tested after the first one hundred miles because of the initial settling down that always occurs in that period.

Should any shake be apparent, adjust the steering head bearings.

Adjust steering head bearings by :

Jack up the front of the machine so that all weight is taken off the front wheel. (A box under each footrest serves that purpose).

Slacken the two fork crown pinch screws.

Slacken the domed nut at top of the steering column.

Screw down the nut underneath the domed nut a little at a time (using adjustable spanner 017249) and, while doing so, test the head assembly for slackness by placing the fingers over the gap between handlebar lug and frame top lug, at the same time exerting upward pressure by lifting from the front edge of the front mudguard. Tested in this manner the slightest slackness is discernable.

Continue to tighten the lower adjusting nut until no perceptible movement can be felt and yet the steering head is perfectly free to turn, then tighten down the domed nut in order to lock the adjustment.

Securely tighten the two fork crown pinch screws (this is very important.)

Remove packing from under footrest.

FRONT FORKS (TELEDRAULIC)

Owing to the unusual construction of the "TELEDRAULIC" fork it is desirable to understand what happens in use and, in order to clearly follow the descriptions and subsequent assembly and adjustment instructions, reference to illustrations 28 and 29 will be necessary.

As will be seen from the general arrangement drawing, illustration 29, the main members of the forks are two long tubes. These are of heavy gauge and are externally ground to very fine limits. These fork main, inner, tubes are firmly fixed to the handlebar clip lug by the top bolts 021830 and are clamped to the fork crown by the clamping screws. Upon the external of these tubes are mounted the springs and sliding members, to which the front wheel mudguard is fixed.

The telescopic action of the sliders, combined with the hydraulic dampers, described later, explain the word "Teledraulic," coined for the description of the fork.

The damping arrangement is shown in Illustration 28 which should be examined if fork dismantling is contemplated.

To disconnect the damper tube from the fork slider a thin wall box key is required to release the damper tube fixing bolt 010697.

Oil leakage from this position is due to a loose bolt or deformed fibre washer.

A rattle in the fork assembly can be due to a disconnected damper rod or low oil content. A scraping noise, when fork movement takes place is due to one, or both fork springs rubbing against the fork cover tube. A small amount of heavy grease applied on the outside diameter of the fork springs will have a beneficial effect.

TO EXPOSE THE FORK SPRINGS

As the fork inner tubes are a close fit in both the handlebar lug and fork crown a draw-bolt, which can be used to drive out and pull back the tubes is available, part No. B.2141A. To give attention to or to change the fork springs, the fork assembly, complete with front wheel and mudguard assembled (leaving the headlamp, etc., in position) can be taken away as a unit.

Raise the front wheel well clear of the ground.

Disconnect the front brake cable, handlebar end.

Remove both fork tube bolts (49) use spanner 018667.

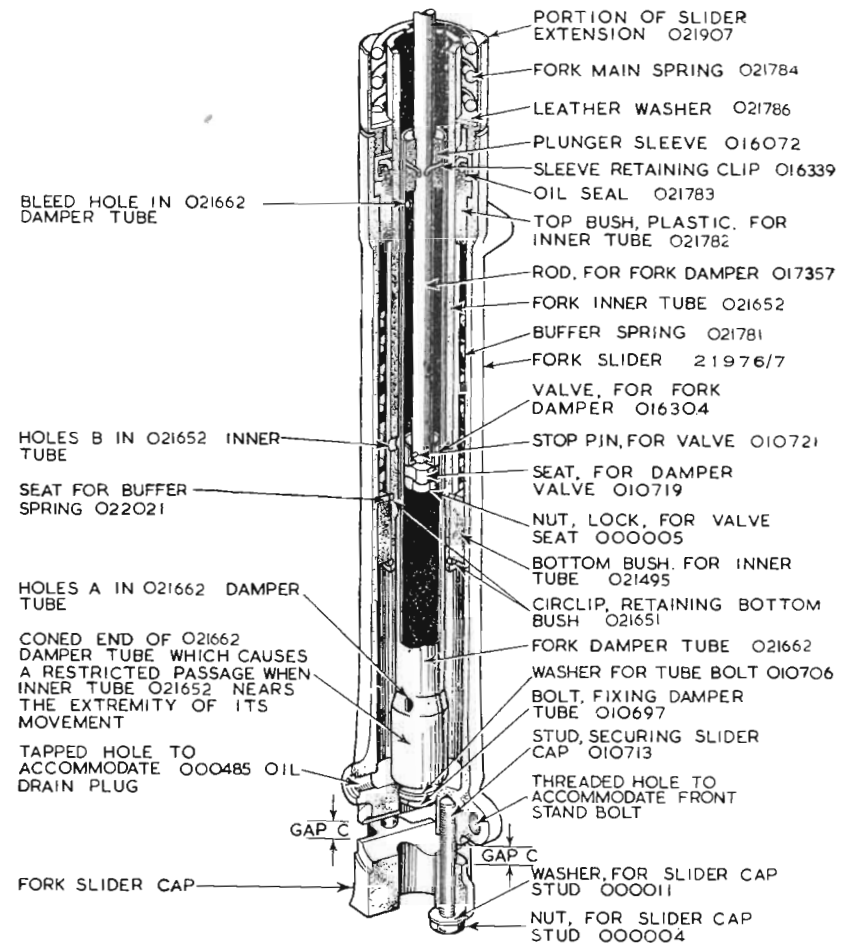

Illustration 28

Disconnect both damper rods, by releasing the lock nut and unscrewing both bolts. Release both fork crown pinch screws (38).

The fork assembly can now be taken away from the machine.

If the fork tubes are a tight fit in the fork crown and handlebar lug, use the drawbolt to tap out each tube alternately a small amount, changing the bolt from one tube to the other, until the tubes are clear of the frame. Lift off the bottom cover tubes to expose the springs.

The figures in parentheses are shown in Illustration 29.

NOTE—If a steering damper is used disconnect damper plate to frame.

TO REFIT THE FORKS AS A UNIT

With the two cover tubes in position, introduce the fork tubes into the fork crown and handlebar lug, lift the assembly then lightly tighten both pinch screws.

Fit the drawbolt through the handlebar lug and pull up each tube a small amount, changing the tool from one tube to the other, to pull the tubes up evenly. With a piece of wire lift up the damper tubes, connect them to the top bolts and firmly tighten the rod lock nut. Replace the top bolts, then very firmly re-tighten the pinch screws.

Re-connect the brake cable to complete the assembly.

FRONT FORK "TOPPING UP"

No part of the **TELEDRAULIC** Front Fork requires individual lubrication, but it is advisable to check the oil content, once every five thousand miles.

Support motor cycle vertically with weight on both wheels. A steady under each footrest is the best method.

Remove the rubber grommet and unscrew the top bolts. Have a graduated measure of not less than 10 fluid ozs. capacity available in which to catch and measure the oil. Remove the drain plug from the bottom of a slider and catch the oil which drains out. If the fork had the correct oil content, about 6 fluid ozs. (170.4 c.c.) will have been drained off. If less, add to make this quantity, or reduce if an excess quantity has been drained off. Next refit drain plug and carefully pour into the top of the tube being checked exactly 6 fluid ozs. (170.4 c.c.) after which the top bolt may be replaced.

NOTE—Although the normal oil content of each side is specified as 6½ fluid ozs., it is not possible to drain all the oil via the drain plug. This explains the lesser quantity of 6 fluid ozs. (170.4 c.c.) referred to above. However, if the fork is at any time completely dismantled and then reassembled in a dry state, it should be noted that in that event the correct quantity of oil to add to each leg is 6½ fluid ozs. (184.6 c.c.).

TO REMOVE THE COMPLETE FRONT FORK ASSEMBLY

Support the machine with the front wheel clear of the ground. (A box, of suitable height, under each footrest is the best method.)

Remove the front wheel as described in Wheel Section.

Remove the front mudguard and stay.

Slacken the screw on head lamp top, gently prise out the rim and reflector assembly, detach with a slight rotary and lifting movement the cap to which head lamp wires are attached. Pull out pilot bulb and take away rim and reflector assembly.

Disconnect the driving cable from the speedometer head and draw same down through fork crown.

Remove the bolts, leaving the head lamp shell, etc., free to be gently suspended by the wiring loom.

Remove the handlebar half clip and lay the handlebars, complete with controls, upon a pad on top of the petrol tank.

Detach the front brake cable from the forks. (First remove the slotted yoke end and then completely unscrew the cable adjuster.)

Remove the rubber grommet and unscrew the top bolt on each inner tube, raise same and slacken the lock nuts securing the damper rods attached. Then, before removing the top bolts, attach a piece of wire about 18 inches long underneath each damper rod lock nut, to enable the damper rods to be raised for reassembly.

Remove domed nut at top of steering column.

Remove lock nut on steering column.

Use a soft mallet to tap upward the handlebar lug until it disengages with the fork stem (steering column) and main tubes. The fork assembly can then be withdrawn. (Take care to avoid loss of any of the 56 steering head steel balls.)

To refit a complete front fork assembly

Secure with grease, 28 balls in fork crown ball race.

Secure, with grease, 28 balls in main frame top ball race.

Proceed to fit fork assembly by reversing the instructions given above to dismantle, carefully re-tightening the damper rod lock nuts before inserting the hexagonal headed plugs to which they are attached.

TO REMOVE A FORK SLIDER

Raise the front wheel clear of the ground.

Unscrew the top fork tube bolt and disconnect the damper rod. Unscrew the screwed slider extension (54).

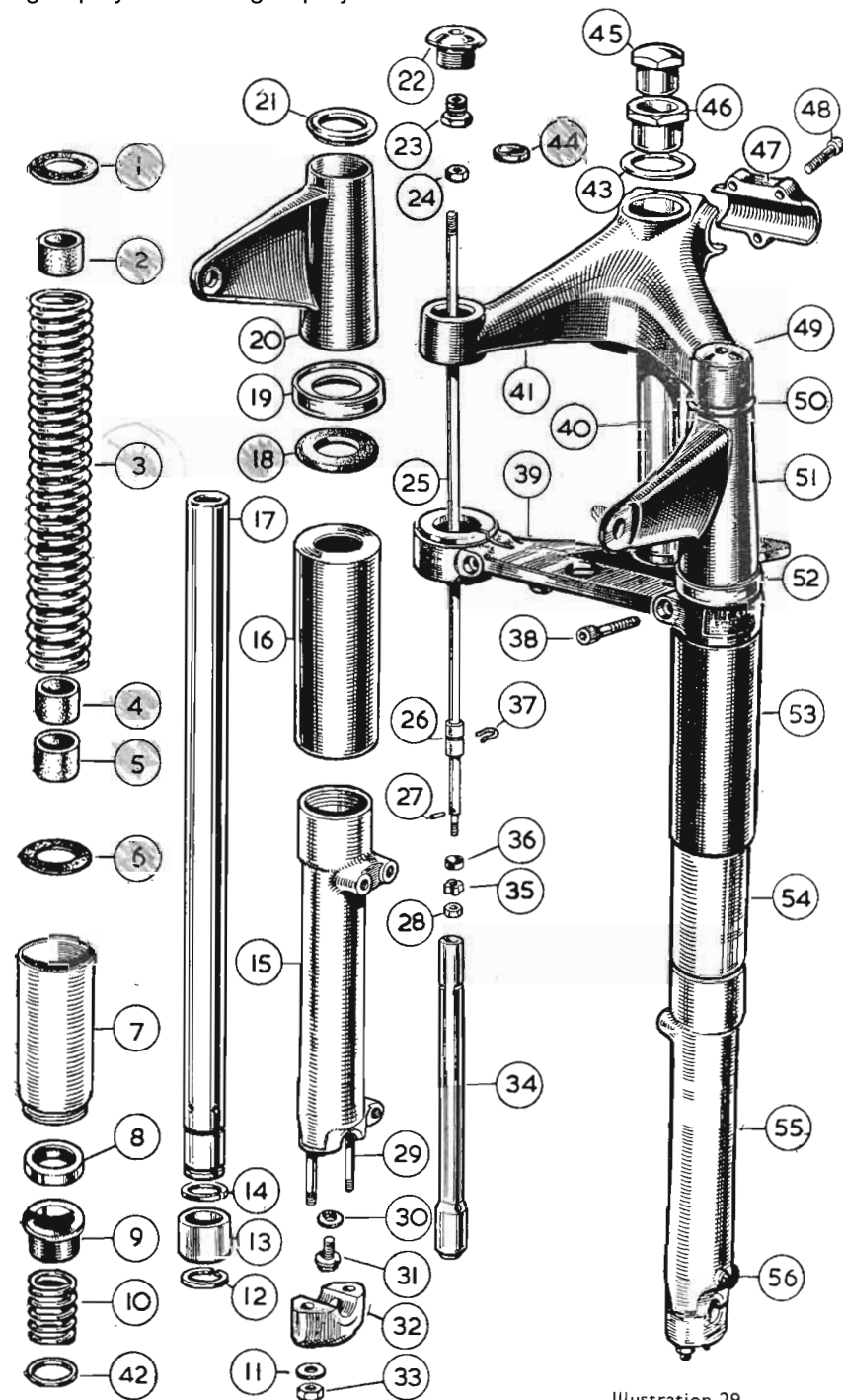

Illustration 29

Exploded view of Teledraulic Forks

REF. NO.	DESCRIPTION
1	WASHER, LEATHER, FOR FORK SPRING TOP SEATING.
2	BUFFER, RUBBER, FOR FORK INNER TUBE.
3	SPRING, MAIN, FOR FRONT FORK.
4	BUFFER, RUBBER, FOR FORK INNER TUBE.
5	BUFFER, RUBBER, FOR FORK INNER TUBE.
6	WASHER, LEATHER, FOR FORK SPRING BOTTOM SEATING.
7	EXTENSION, FOR FORK SLIDER.
8	OIL SEAL, FOR FORK INNER TUBE.
9	BUSH, TOP, PLASTIC, FOR INNER TUBE.
10	SPRING, BUFFER, FOR FRONT FORK.
11	WASHER, PLAIN, FOR FORK SLIDER CAP SECURING STUD.
12	CIRCLIP, LOCATING FORK INNER TUBE BOTTOM BUSH.
13	BUSH, BOTTOM, STEEL, FOR FORK INNER TUBE.
14	CIRCLIP, LOCATING, FORK INNER TUBE BOTTOM BUSH.
15	SLIDER, FOR FORK, WITH STUDS (RIGHT SIDE).
16	TUBE, FORK COVER, BOTTOM.
17	TUBE, FORK, INNER.
18	RUBBER RING FOR TOP COVER TUBE HOUSING RING.
19	HOUSING RING, TOP COVER TUBE.
20	TUBE, FORK COVER, TOP, RIGHT, WITH LAMP LUG.
21	SPIGOT RING TOP COVER TUBE.
22	BOLT, TOP, FOR FORK INNER TUBE.
23	ADAPTOR.
24	NUT, LOCK, FOR TOP END OF DAMPER ROD.
25	ROD, FOR FORK DAMPER.
26	SLEEVE, PLUNGER, ON FORK DAMPER ROD.
27	PIN, STOP, FOR FORK DAMPER VALVE.
28	NUT, LOCK, FOR DAMPER VALVE SEAT.
29	STUD, SECURING CAP TO FORK SLIDER.
30	WASHER, FIBRE, FOR DAMPER TUBE BOLT.
31	BOLT, FIXING DAMPER TUBE TO SLIDER.
32	CAP, FOR FORK SLIDER.
33	NUT, FOR FORK SLIDER CAP SECURING STUD.
34	TUBE, FOR FORK DAMPER.
35	SEAT, FOR FORK DAMPER VALVE.
36	VALVE, FOR FORK DAMPER.
37	CLIP RETAINING DAMPER ROD SLEEVE.
38	SCREW, PINCH, FOR FORK CROWN.
39	FORK CROWN
40	STEM, FOR FORK CROWN } NOT SOLD SEPARATELY.
41	LUG, FOR HANDLEBAR AND STEERING HEAD.
42	COLLAR FOR BUFFER SPRING.
43	WASHER FOR FORK STEM ADJUSTING NUT.
44	RING, RUBBER, SEALING, FOR INNER TUBE TOP BOLT.
45	NUT, LOCK, FOR FORK STEM.
46	NUT, ADJUSTING, FOR FORK STEM.
47	CLIP (HALF ONLY), FOR HANDLEBAR LUG.
48	SCREW, PINCH, FOR HANDLEBAR CLIP.
49	BOLT, TOP, FOR FORK INNER TUBE.
50	SPIGOT RING TOP COVER TUBE.
51	TUBE, FORK COVER, TOP, LEFT, WITH LAMP LUG.
52	HOUSING RING TOP COVER TUBE.
53	TUBE, FORK COVER, BOTTOM.
54	EXTENSION, FOR FORK SLIDER.
55	SLIDER FOR FORK WITH STUDS (LEFT SIDE).
56	SCREW, PLUG, WITH FIBRE WASHER, FOR FORK SLIDER OIL DRAIN HOLE.

N.B.—WASHER (43) DELETED FROM ASSEMBLY.

Next remove the front wheel, mudguard and stay.

The oil seal is a close fit in the enlarged end of the slider and should difficulty occur in removing the slider, apply gentle heat at the position where the oil seal is located which will cause the slider to expand. A sharp jerk downwards will separate the slider from the oil seal, which will come away with the damper tube and rod assembly. The re-assembly is carried out in the reverse order pull up the damper rods as already described but finally tighten the screwed extension after the wheel is fitted. If oil is lost during this process, see details for "tapping up."

TO REMOVE A FORK INNER TUBE

Start by removing the fork slider, release the pinch screw in the fork crown, the tube can then be pulled or driven out from the handlebar and fork crown lug.

REAR SUSPENSION

The rear wheel is mounted in a fork that is hinged just behind the gear box. The hinge has robust plain bearings lubricated from a reservoir of $1\frac{1}{2}$ fluid ounces (42.6 c.c.) of heavy gear oil which is sufficient to last almost indefinitely. Provision is, however, made for replenishment should same be required. A small screw will be observed in the right-hand end cap of the hinge bearing, upon removal of this screw, oil can be injected into the reservoir, the screw orifice operating as a level control.

On a new machine, or after replenishment, oil may leak from this bearing. This is of no consequence and the leakage will cease after a few hundred miles have been covered.

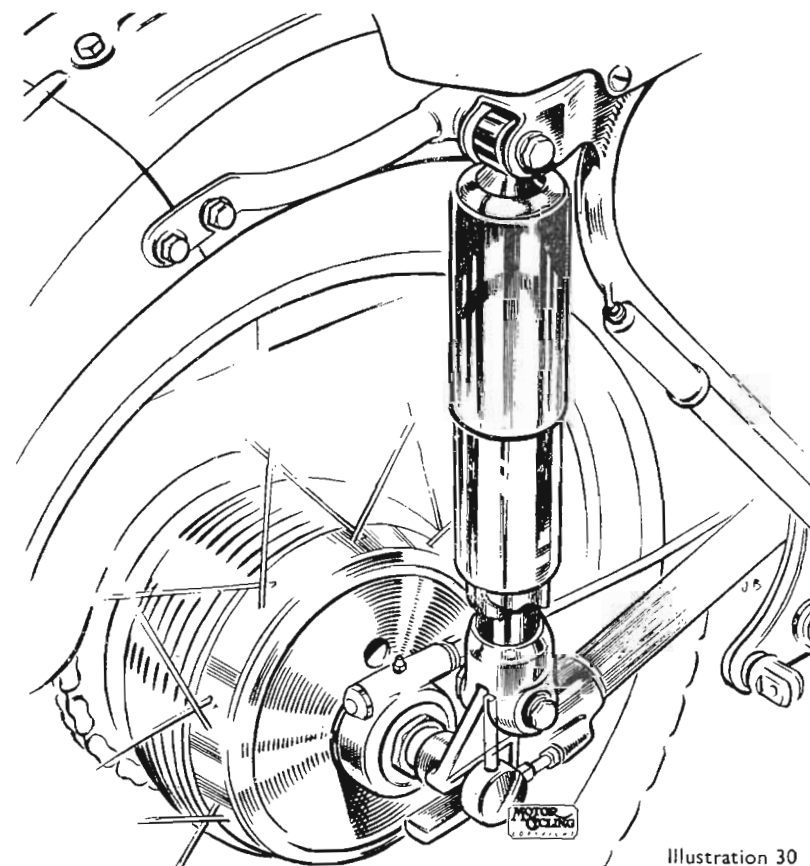

Illustration 30

The rear wheel fork is suspended on springs located in the two suspension units joining the rear fork to the main frame loops.

The suspension units are of the sealed unit type, and topping up is not necessary. The springs are lubricated before assembly and the fluid in the damper unit is the exact quantity and sufficient for the unit's life.

An exploded view of the suspension unit is shown in illustration 31.

Maintenance is confined to external cleaning and occasional greasing of the cam ring adjuster.

Should a squeak or rubbing noise develop as the units move, remove the split collar securing the top cover tube, remove unit top fixing bolt, take off the tube and apply grease on the outside diameter of the spring.

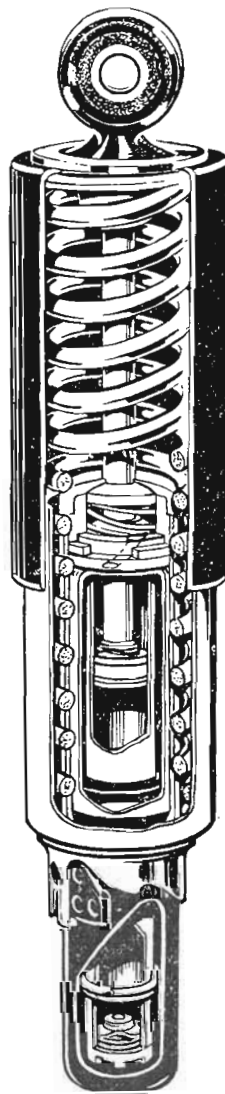

Illustration 31

"Ghost" view of Suspension Unit

THE CAM RING ADJUSTER

Raising the base of the spring by turning the cam ring clockwise (see illustration 31), pre-loads the spring for varying loads.

Stronger springs are available for use when a sidecar is attached to the machine.

PROP STAND

The prop stand hinges on a bolt which passes through a lug brazed to the frame and screws into the jaw of the stand leg. It is then locked by a nut and split pin. Care in tightening this bolt is necessary to avoid pinching, and it is essential to observe after securely tightening the lock nut that the stand is perfectly free. Smear the hinge bolt with engine oil before replacing it.

CENTRE STAND

The centre stand is mounted on a bolt set across the bottom rear of the main frame and is removed by taking off a nut of the centre bolt and pushing bolt through the frame. During removal and replacement the stand should be in a horizontal position in order to take off as much of the tension off the return spring as is possible.

TO REMOVE OIL TANK

Remove the twinseat.

Remove the frame cover. It is held in position by two large knurled and slotted screws.

Remove the oil tank drain plug and empty the tank.

Disconnect the oil feed and return pipes from the bottom of the tank.

The tank is held in position by four brackets and nuts and bolts, two at the top, one at the front, and one at the back.

Remove the nuts, bolts and washers, lift the tank away from the frame a few inches, and disconnect the vent pipe. The tank is now free. To refit, reverse the foregoing instructions.

TO REMOVE THE REAR CHAIN GUARD

Remove the rear wheel. (See Wheel Section.)

Remove the bolt retaining the front end of the chain guard to the rear fork.

Remove the bolt retaining the rear end of the chain guard to the rear fork. (There is one spacer on this bolt, between the two sides of guard.)

WHEELS AND BRAKES

TO REMOVE FRONT WHEEL

Place machine on centre stand.

Remove the split pin, and pin, retaining yoke end of front brake cable to the brake expander lever.

Remove bolt retaining brake anchor stay to brake cover plate.

Slacken the nut on the left-hand end of front wheel spindle.

Remove the four nuts retaining the caps to the fork sliders, which will permit the removal of the two caps and, putting pressure on the front wheel (in order to decrease the effective height of the wheel spindle) the wheel can be withdrawn towards the front.

NOTE—The two caps **MUST** be refitted in same order and position as originally. Therefore, lay them aside so that the order and position of assembly will be correctly made.

TO RE-FIT FRONT WHEEL

Holding the left side cap on the wheel spindle, offer wheel up so as to engage the cap with its securing studs. Then apply fixing nuts and washers but only loosely tighten.

NOTE—To pass the wheel spindle into position it may be necessary to apply pressure to flatten the tyre so as to enable the spindle to pass the forward fixing studs.

Next fit the right side cap and again only loosely tighten the securing nuts. Now attach the brake anchor arm, firmly tighten retaining bolt and refit yoke end and pin.

Next fully tighten the nuts securing the left side cap, taking care to keep the gap fore and aft approximately equal. Then tighten the left side spindle nut and lastly the nuts securing the right side cap.

Should any fork stiffness be apparent after refixing the front wheel, loosen the nuts securing the right side cap and after working the fork up and down violently, retighten. This action will ensure that the wheel clamp occupies its natural position on the spindle end on which it is intentionally not positioned.

TO REMOVE QUICKLY DETACHABLE REAR WHEEL

Place the machine on the centre stand. Loosen the bolt in the rear most position on each tubular member to which the detachable rear portion of the mudguard is secured. Also slacken off the two bolts securing the two portions of mudguard together. Disconnect the snap connectors of the rear lamp wire when the rear portion of mudguard is free to be taken away. **DO NOT LOOSEN NUT SECURING SPEEDO GEAR BOX.**

Disconnect speedometer drive by unscrewing the cable gland nut and withdrawing drive cable end from the speedometer gear box. Then remove the wheel spindle end nut and washer and withdraw spindle together with distance collar which will fall as spindle is withdrawn. The wheel is now free to be removed.

In refitting it will be found best to offer up the wheel, insert spindle without the distance collar and after engaging the driving pegs hold wheel in situ, withdraw the spindle and insert the distance collar.

Upon tightening the spindle end nut make certain the collar end of the spindle is in contact with the chain adjusting screw to ensure correct wheel alignment. Also see that the speedometer gear box is positioned correctly.

WHEEL BEARINGS AND ADJUSTMENT

The wheel bearings are of taper roller type (see illustrations 33 and 34). The outer cups for the rollers are pressed into the hub shell. They have a fixed location one side and an adjustable location on the other. The fixed location is provided by a circlip in a groove cut in one end of the hub shell, while the adjustable location is regulated by a screwed ring that is threaded into the opposite end of the hub and the position of which can be locked by an encircling nut.

On each wheel the adjusting ring is located on the right-hand side.

It is rarely necessary to make adjustment to wheel bearings. It is most important they are not adjusted too tightly as this would quickly ruin them. There must always be a slight amount of end play. This should be about .002", which represents a just perceptible rim rock.

A service method of ensuring correct adjustment is :

Slacken the lock nut.

Tighten the adjusting ring until all slackness has been taken up.

Slacken back the adjusting ring exactly one-half turn.

Tighten the lock nut, making sure that, when doing so, the adjusting ring does not creep round, and the cover disc positioned to permit grease gun application to the nipple.

TO DISMANTLE FRONT WHEEL BEARINGS

Refer to Illustration 33, page 67.

Remove wheel from machine.

Remove nut securing brake cover plate, withdraw cover plate with brake shoes, etc.

Then remove brake cover positioning nut and washer.

Then turn to the right hand side of wheel, remove adjusting ring lock nut and lift off cover disc.

Then completely unscrew the adjusting ring.

Now carefully apply pressure to the threaded end of the wheel spindle which will eject from the opposite end of the hub, the washer (7), oil seal (8) and oil seal cup (9), together with the bearing outer ring (6). The wheel spindle with its two sets of rollers in cages may now be lifted out leaving in situ only the fixed bearing ring together with the oil seal, washer and cup for that side bearing.

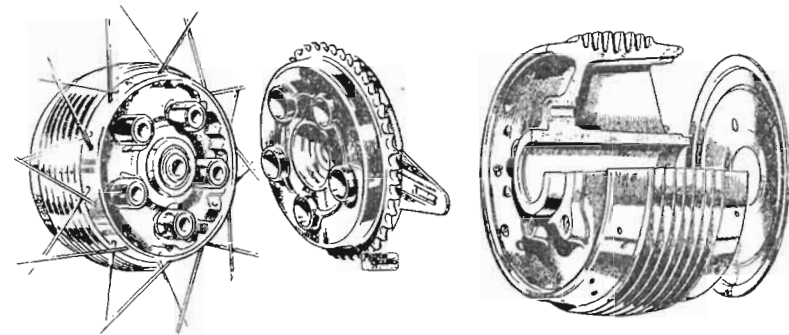

Front and rear hubs

Illustration 32

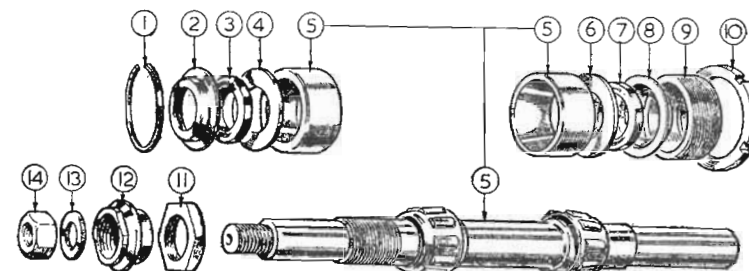

- 1 CIRCLIP.
- 2 OIL SEAL CUP.
- 3 OIL SEAL.
- 4 WASHER RETAINING SEAL.
- 5 WHEEL SPINDLE COMPLETE.
- 6 WASHER RETAINING SEAL.
- 7 OIL SEAL.

- 8 OIL SEAL CUP.
- 9 ADJUSTING RING.
- 10 ADJUSTING RING LOCKNUT.
- 11 NUT LOCATING BRAKE COVER PLATE.
- 12 NUT SECURING BRAKE COVER PLATE.
- 13 SPINDLE END WASHER.
- 14 SPINDLE END NUT.

Front wheel bearings

Illustration 33

If it is desired to remove these pressure is first applied to the visible washer, by which the assembly is forced inward sufficiently to permit extraction of the retaining circlip after which through the medium of a mandrel or a piece of tubing of external diameter a trifle smaller than the hub bore apply pressure to the inner edge of the fixed bearing ring so that it is forced out of the hub end. As it emerges it will push out the end washer (2), the oil seal (3) and the oil seal encircling collar (4) and the inner washer (5).

To refit reverse the above procedure remembering that after bearing ring (6), washer (5), spacer (4), oil seal (3) and washer (2) have been inserted, to refit the circlip (1) snugly in its groove and to then apply pressure to the inner edge of the bearing ring to force the assembly tightly back against the retaining circlip.

Finally position the disc when tightening the adjusting ring lock nut so that access to the grease nipple is possible.

TO DISMANTLE REAR WHEEL BEARINGS

Refer to Illustration 34.

With wheel still in situ first of all slacken the nut (16) securing the speedometer drive gear box. Then remove the wheel from cycle when the above nut should be removed and the speedometer gear box withdrawn.

Next, slacken the adjuster sleeve lock nut (13) and completely unscrew the adjuster sleeve (14) which will come away together with the sleeve upon which speedometer drive is mounted and also the cover disc. Then withdraw the washer (3) the oil seal (4) and the oil seal cup (5).

Now turn to the brake side of wheel and using a short bar of $\frac{7}{8}$ " external diameter apply pressure to the end of the projecting sleeve, which pressure will force out wheel bearing ring (7) together with the two taper roller bearings (7) and the spacing sleeve (8), leaving in situ only the bearing ring on the brake side together with oil seal, washers and retaining circlip.

If it is desired to remove this spacer bearing ring pressure must be applied to the cup washer immediately under the circlip until it is possible to extract the circlip. The outer cup washer (5) the oil seal (4) and the spacer (6), etc., are then free to be withdrawn. The bearing ring may then be forced out of the end of the hub bore by applying pressure to its inner edge through the medium of a bar or tube of suitable diameter passed through the hub bore.

Re-assembly is carried out in exactly reverse order, care being necessary after pressing in the brake side bearing ring sufficiently far to permit fitting the circlip, to then force the ring back until cup washer (5) is tightly in contact with the retaining circlip before proceeding with further assembly.

Final adjustment of the bearings should allow the slightest possible degree of end play and when correctly adjusted just perceptible rim rock upon refitting the wheel should be observable.

NOTE—Upon tightening the adjusting ring nut (13) the cover disc must be positioned to permit application of the gun to the grease nipple, the hole in disc being provided for that purpose.

FRONT BRAKE COVER PLATE

It is most important the front brake cover plate is correctly positioned.

It is retained to the front wheel spindle by an inside nut (part number 021931) and an outside nut (part number 018171).

The inside nut must be positioned so that, when the cover plate is applied, the outer face of the latter lies flush with the hub shell edge.

The outside nut is fitted so that its hexagonal side is against the brake cover plate.

BRAKE DRUMS

The front wheel brake drum is cast in the hub shell.

The rear brake drum is mounted on a separate ball bearing and the drive to rear wheel is by means of five studs projecting from the hub face which engage with holes in the drum back face, thereby permitting removal of the rear wheel with the brake drum still in situ.

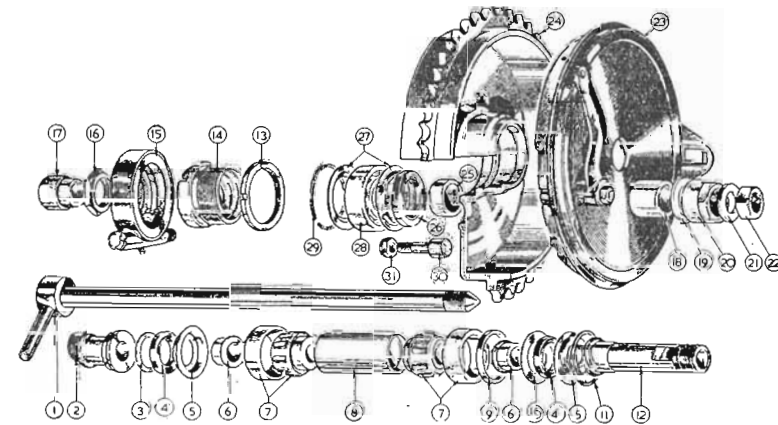

Rear brake and wheel bearings

Illustration 34

- | | |
|--|--|
| 1 WITHDRAWABLE WHEEL SPINDLE. | 17 SPACER FOR WITHDRAWABLE SPINDLE. |
| 2 SPEEDOMETER GEAR BOX SLEEVE. | 18 OUTER SPACER FOR BRAKE COVER PLATE. |
| 3 RING RETAINING OIL SEAL (Small). | 19 WASHER FOR COVER PLATE FIXING NUT. |
| 4 OIL SEAL. | 20 BRAKE COVER PLATE FIXING NUT. |
| 5 CUP FOR OIL SEAL. | 21 SPINDLE END WASHER. |
| 6 OIL SEAL DISTANCE PIECE. | 22 SPINDLE END NUT. |
| 7 TAPER ROLLER BEARING COMPLETE. | 23 BRAKE COVER PLATE COMPLETE. |
| 8 SPACER BETWEEN BEARINGS. | 24 REAR BRAKE DRUM. |
| 9 BEARING SPACING COLLAR (Brake Side). | 25 INNER SPACER FOR BRAKE COVER PLATE. |
| 10 RING RETAINING OIL SEAL (Large). | 26 BRAKE DRUM BEARING OIL SEAL. |
| 11 CIRCLIP. | 27 BRAKE DRUM OIL SEAL WASHERS. |
| 12 BRAKE DRUM DUMMY SPINDLE. | 28 BRAKE DRUM BALL BEARING. |
| 13 LOCK NUT FOR ADJUSTING RING. | 29 CIRCLIP RETAINING BEARING. |
| 14 ADJUSTING RING. | 30 DRIVING PEG (5 Off). |
| 15 SPEEDOMETER GEAR BOX COMPLETE. | 31 NUT SECURING DRIVING PEG (5 Off). |
| 16 SPEEDOMETER GEAR BOX FIXING NUT. | |

BRAKE SHOES

The front and rear brake shoes, springs and expanders are interchangeable. The two shoes in each brake are **NOT** identical, they are "handed."

One end of each shoe bears on a fulcrum fixed in the brake cover plate. The other end accommodates a detachable thrust pin. By inserting washers under a thrust pin its effective height can be increased, thereby compensating for wear on the brake linings.

BRAKE SHOE ADJUSTMENT

Brake adjustment, to compensate for lining wear, is normally made by means of a finger adjuster on the rear brake rod and a cable adjuster for the front brake cable.

After a very considerable mileage this continual adjustment causes the brake cam to occupy a position whereby the available leverage is considerably reduced and, as a result, the brake loses efficiency. See illustrations 35 and 36.

To overcome this a hardened headed thrust pin is fitted to each shoe to enable a packing washer to be fitted under the head as, and when, required. Eight of these washers (000174) are provided in the tool kit. When wear of the brake linings is taken up in this manner it is then necessary to unscrew considerably the adjusting nut on the rear brake rod, or screw in the cable adjuster of the front brake cable, and afterwards adjust the brake, as described afterwards.

When a brake cover plate has been disturbed, it is advisable, upon re-assembly, to centralise the shoes in the brake drum to ensure equal pressure to each. In the case of the front wheel this is best done before refitting the wheel to the machine, but in the case of the rear wheel it is best done after refitting.

If brake shoes tend to squeak, when the brake is applied it is generally an indication the brake shoes are not centralised in the drum.

Centralise brake shoes by :

Ensure the nut securing the cover plate to the wheel spindle and also the fulcrum stud nut (front only) are slightly slacked off.

Place on the brake expander lever a tubular spanner (to increase the leverage), and, while maintaining pressure on the tubular spanner (to expand fully the brake shoes), fully tighten the spindle nut binding the cover plate to the spindle and also the nut on fulcrum stud.

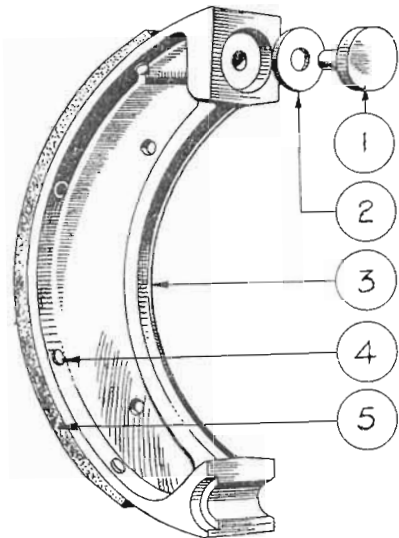

- (1) Brake shoe thrust pin.
- (2) Thrust pin packing washer.
- (3) Brake shoe.
- (4) Rivet, securing brake shoe lining.
- (5) Brake Shoe Lining.

Illustration 34A

FRONT BRAKE ADJUSTMENT

Major adjustment of the front brake shoes is made on the brake thrust pins, by fitting packing washers under the pins, as already described.

Minor adjustment of the front brake shoes is made by altering the position of the brake cable adjuster on the fork assembly. Unscrew the adjuster to "take up" the front brake.

The adjuster is locked in position by a nut.

Adjust front brake by :

Place machine on centre stand.

Slacken lock nut on cable adjuster.

Unscrew the cable adjuster till, by rotating the front wheel, it can be felt the brake shoes are just touching the brake drum.

Then screw back the adjuster two complete turns and tighten the lock nut.

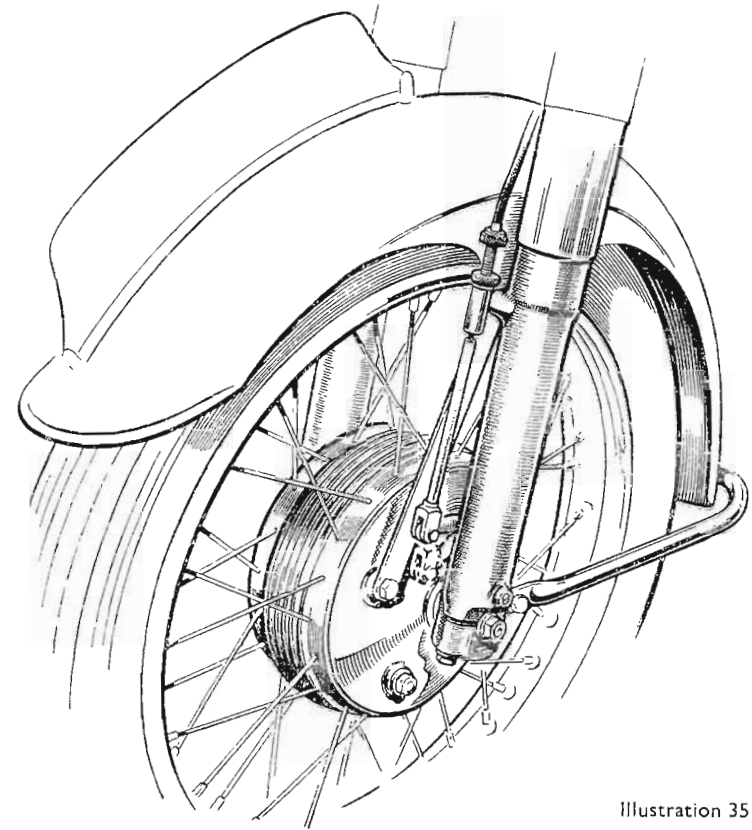

Illustration 35

Showing front brake cable adjuster thread exhausted, indicating brake shoe thrust pin adjustment is necessary.

REAR BRAKE ADJUSTMENT

Major adjustment of the rear brake shoes is made on the brake thrust pins, by fitting packing washers under the pins, as already described.

Minor adjustment of the rear brake shoes is made by altering the position, on the brake rod, of the knurled adjusting nut. Screw the nut further on the rod to "take up" the rear brake.

Adjust rear brake by :

Place machine on centre stand.

Screw further on the brake rod the knurled adjusting nut till, by rotating the wheel, it can be felt the brake shoes are just touching the brake drum.

Then unscrew the adjusting nut five complete turns. (The adjusting nut is automatically locked in position by virtue of the two projecting noses on it engaging in accommodating slots cut in the clip which connects the brake rod and brake expander lever and being retained in that position by the spring which encircles the rear end of the brake rod),

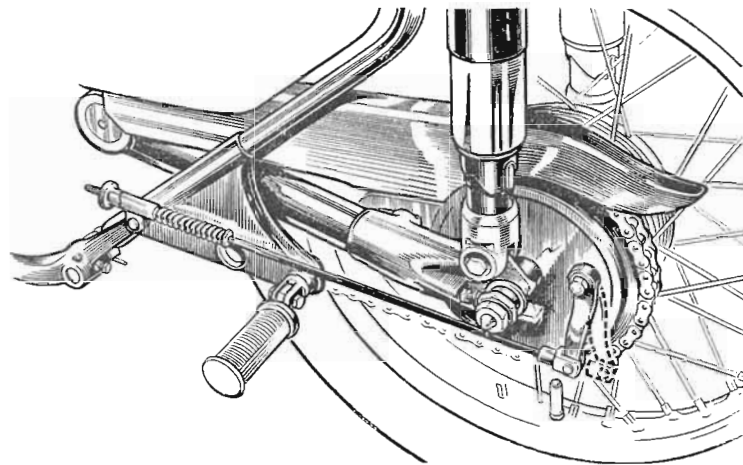

Illustration 36

Showing brake rod adjustment exhausted, indicating the need for brake thrust pin adjustment.

BRAKE PEDAL ADJUSTMENT

The pedal is located by a spring-loaded sprag which lies between the stop on the pedal and the leg of hair pin spring.

To adjust the position of the pedal: slacken the spindle nut on the right hand side of the machine; move the pedal to the desired position; hold the pedal in this position and tighten the spindle nut.

The most suitable position for normal use is, with the brake "OFF," for the pedal just to be clear of the footrest rubber.

After altering the pedal position, check the rear brake adjustment.

TYRES AND SERVICE

Obtaining satisfactory life and service from the tyres is largely a matter within the user's control because the first essential is correct inflation. Check tyre pressures with a low pressure gauge at least once a week. Inflate as may be necessary.

Avoid unnecessary, or "stunt," acceleration and fierce braking, which wear out tyres by causing wheel spin and skid.

Do not drive in tram lines. It is dangerous, especially when wet, and the uprising edges of worn rails will damage the tyres.

Remove flints, etc., that become embedded in the tread and, if any oil gets on the tyres or spacers, clean it off with petrol.

Make sure the front and rear wheels are in track. When the wheel alignment is correct, a piece of thin string stretched taut across both wheels, about four inches from, and parallel to, the ground, should just touch each tyre at both sides of the wheel centres.

Alternatively, a straight wooden batten, about seven feet long, is handy to use for checking wheel alignment. This should be applied, as in the case of string, parallel to and about four inches from the ground.

Always check the rear chain adjustment, and the rear brake adjustment, after making an alteration to the rear wheel position.

NOTE—Above remarks on wheel alignment apply only to similar width tyres back and front.

On models with larger rear tyre than front observe equal gap each side of latter when checking.

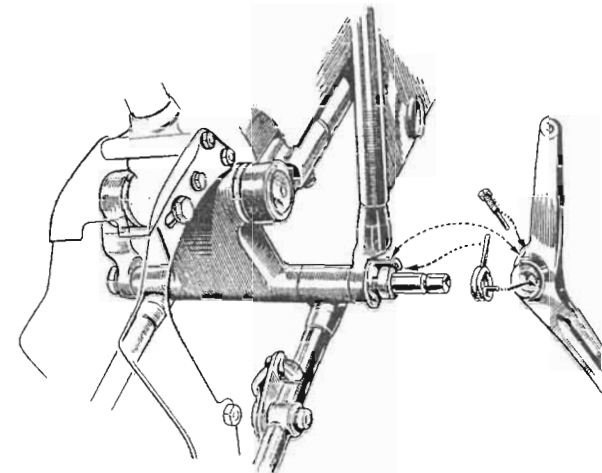

Pedal Position Adjustment

Illustration 37

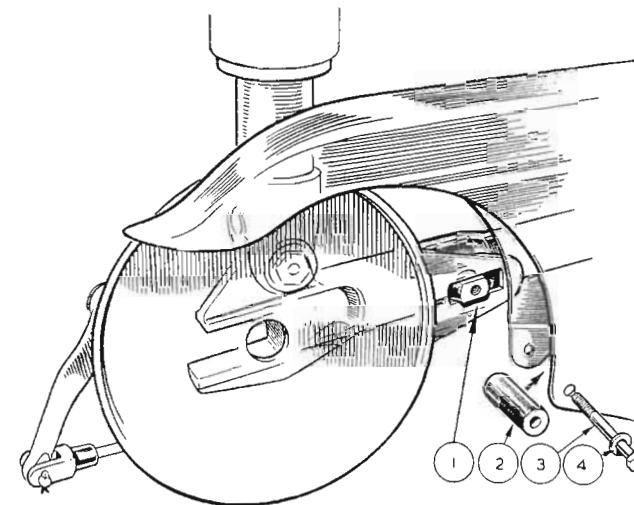

Brake Anchorage—Illustration 38

- 1 BRAKE ANCHORAGE BOSS.
- 2 SPACER.

- 3 FIXING BOLT
- 4 WASHER.

TYRE REMOVAL

It is not essential to remove a wheel from the machine to repair a puncture but it will usually be found desirable and more convenient to do so.

Take off outer cover and remove inner tube by :

Remove cap from tyre valve.

Remove nut from tyre valve.

Remove the "inside" from tyre valve. This allows inner tube to deflate. Most valve caps have a reduced and slotted top to engage with the valve "inside" in order to unscrew it.



Push edge of cover, that is diametrically opposite to the valve, **RIGHT INTO WELL OF RIM** and, using tyre levers 017007, pick up edge of cover **NEAR VALVE** so that it comes off over the edge of the rim.

Work off the remaining edge of the cover till it is clear of the rim. This is quite easy and there is no reason to use force.

Push upwards **valve stem** through its hole in the rim, and the inner tube is then free to be taken away.

Remove cover from rim by pushing it right into well of rim and, diametrically opposite, picking it up with the tyre lever and then working it off all the way round.

TYRE FITTING

Re-fit inner tube and outer cover by :

Place one edge of cover right into well of rim, with the three white dots on the cover side **adjacent to the valve hole**, and, commencing diametrically opposite, and using the hands only, work the cover over the edge of the rim.

Replace the valve "inside" and slightly inflate the inner tube. (Do not distend the tube.)

Fit the valve into its hole in the rim and replace its nut, only screwing it on the valve stem about half an inch.

Tuck in the inner tube so that it lies snugly in the cover. Ensure it is not twisted.

Smear some soapy water round the free edge of the cover. This is a great help in fitting and in ensuring the cover centralises itself on the rim and should always be employed if at all possible.

Introduce the free edge of the cover into the rim at the spot diametrically opposite to the valve. Get this edge right into the well of the rim and then, by working round the cover, equally on either side of the valve position, the cover will slip into place without excessive exertion, fitting the part nearest to the valve last of all.

Slightly inflate the inner tube and inspect for the inner tube being trapped between the outside edge of the cover and the rim at the spots where the valve is located.

Half inflate tyre, spin wheel and test for trueness because it is essential the pattern of the tread runs evenly and the cover must be manipulated till that occurs. This **centralisation of the cover is most important.**

Inflate to required pressure.

Screw fully home the nut on the valve.

Replace the valve cap.

TYRE PRESSURES

The following are correct minimum inflation pressures for specified loads per tyre :

Load per tyre, 200 lb.	Pressure 16 lb. per square inch
do. 240 lb.	do. 18 lb.
do. 280 lb.	do. 20 lb.
do. 350 lb.	do. 24 lb.
do. 400 lb.	do. 28 lb.
do. 440 lb.	do. 32 lb.

The best method of ascertaining the correct pressure is to actually weigh the loads on the front and rear tyres. This should be done on a weighbridge and is a service that can usually be provided by British Railways at a Goods Depot or by a Corporation at its Depot.

When the weights are known the table above can then be used.

As a rough guide it may be stated that, with a rider of average weight and with normal equipment, solo, the pressures should be 18 lb. for the front tyre and 22 lb. for the rear.

ELECTRICAL SERVICE

SINGLES

LUCAS A.C. LIGHTING-IGNITION UNIT

ALTERNATOR MODEL RM15

The alternator consists of a spigot-mounted 6-coil laminated stator bolted to the outer portion of chaincase with a rotor carried on and driven by an extension of the crankshaft. The rotor has an hexagonal steel core, each face of which carries a high energy permanent magnet keyed to a laminated pole tip. The pole tips are riveted circumferentially to brass side plates, the assembly being cast in aluminium and machined to give a smooth external finish.

Thus there are no rotating windings, commutator, brush-gear, bearings or oil seals and consequently the alternator requires no maintenance apart from occasionally checking the snap connectors in the three output cables are clean and tight, which are located between the rear engine plates.

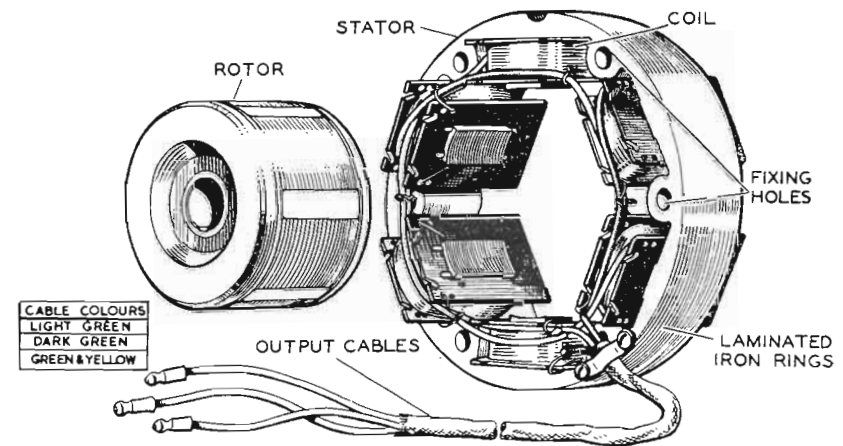

Illustration 39—Alternator

If it is necessary, for any purpose, to remove the rotor, there is no necessity to fit keepers to the rotor poles. When the rotor is removed wipe off any metal swarf which may have collected on the pole tips. Place the rotor in a clean place.

NORMAL RUNNING

Under normal running conditions (i.e., ignition switch in IGN position) electrical energy in the form of rectified alternating current passes through the battery from the alternator—the rate of output depends on the position of the lighting switch. When no lights are in use, the alternator output supplies the ignition coil and trickle-charges the battery. When the lighting switch is turned, the output is automatically increased to meet the additional load of the parking lights and again when the main bulb is in use.

EMERGENCY STARTING

An EMERGENCY starting position is provided in the ignition switch for use if the battery has become discharged. Under these conditions, the alternator is connected direct to the ignition coil, allowing the engine to be started independently of the battery.

Once the engine is running, turn the ignition switch back to the normal running position, otherwise misfiring will occur.

RECTIFIER

The rectifier is a device to allow current to flow in one direction only. It is connected to provide full-wave rectification of the alternator output. The rectifier is mounted on the tool box under the twin seat.

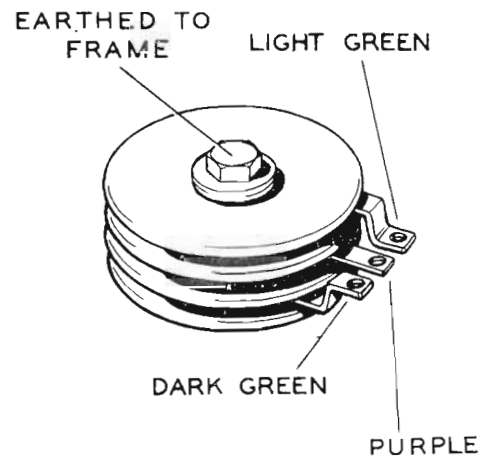

Illustration 40—Rectifier

The rectifier requires no maintenance beyond checking that the connections are clean and tight. **The nut clamping the rectifier plates together must not under any circumstances be slackened, as it has been carefully set during manufacture to give correct rectifier performance.** A separate nut is used to secure the rectifier to the frame of the motor cycle.

NOTE—It is important to check periodically that the rectifier is firmly attached to its mounting bracket.

LUCAS COIL IGNITION

The coil is clipped to the front frame top tube underneath the petrol tank.

The ignition equipment comprises a model MA6 ignition coil and a model CA1A contact breaker unit. The contact breaker, together with an automatic timing control, are located in the engine timing case.

The automatic timing control is centrifugal operated and varies the firing point according to the speed of the engine.

Lubrication—to be carried out every 6,000 miles.

No grease or oil must be allowed to get on or near the contacts when carrying out the following procedure.

Smear the surface of the cam very lightly with Mobilgrease No. 2, or, if this is not available, clean (SAE 30-40) engine oil may be used.

If a felt wick is fitted, squeeze a little grease into the felt.

Place a spot of clean engine oil on the contact breaker pivot.

Remove the central fixing bolt and inject a small amount of clean engine oil into the hole thus exposed. When the fixing bolt has been replaced and the engine run for a few minutes, the oil will be forced out over the automatic advance mechanism by centrifugal force.

Cleaning—every 6,000 miles

Examine the contact breaker. The contacts must be free from grease or oil. If they are burned or blackened, clean with fine carborundum stone or very fine emery cloth, afterwards wiping away any trace of dirt or metal dust with a clean petrol moistened cloth. Cleaning of the contacts is made easier if the contact breaker lever carrying the moving contact is removed.

To remove the moving contact, unscrew the nut securing the end of the spring and remove the nut, spring washer and bush. Lift the contact breaker lever off its pivot.

After cleaning, check the contact breaker setting.

CONTACT BREAKER SETTING

The contact breaker gap should be checked after the first 500 miles running and subsequently every 3,000 miles. To check the gap, turn the engine over slowly until the contacts are seen to be fully open, and insert a feeler gauge between the contacts.

The correct gap setting is 0.014"—0.016".

If the gap is correct, the gauge should be a sliding fit. (Make sure the gauge is clean and oil free before use.)

To adjust the gap, keep the engine in the position giving maximum contact opening and slacken the screws securing the fixed contact plate. Adjust the position of the plate until the gap is set to the thickness of the gauge, and tighten the securing screws.

THE IGNITION COIL

The coil requires no attention whatever beyond keeping its exterior clean, particularly the terminals, and occasionally checking that the connections are tight.

When the high tension cable shows signs of perishing or cracking it must be renewed, using 7 mm. p.v.c.-covered or neoprene-covered rubber ignition cable.

To remove the old cable from the ignition coil, pull the cable together with its connector from the moulded terminal socket. It is advisable to fit new connectors when renewing ignition cables.

ELECTRICAL SERVICE

TWINS

ELECTRICAL EQUIPMENT

LUCAS electrical equipment is fitted and this comprises three independent electrical circuits, as follows :

- (1) **IGNITION**—Magneto, High-tension wires, Sparking plugs and Cut-out switch.
- (2) **CHARGING**—Dynamo Automatic Voltage Control Unit and Battery.
- (3) **LIGHTING AND ACCESSORIES**—Lamps, Horn, Switches and wiring.

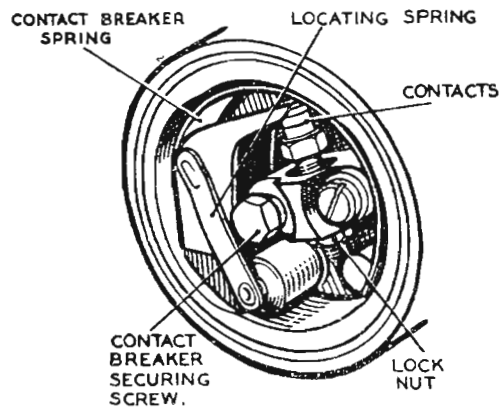

Illustration 41
Contact Breaker

IGNITION

A LUCAS type **K2F** magneto is fitted. The replacement part number is 42230-A and the part number of the complete contact breaker is 470534.

Lubrication and adjustment is required every 3,000 miles, cleaning is required every 5,000 miles and every 10,000 miles the complete unit should be handed to a **Lucas Service Station** for dismantling, replacement of worn parts, cleaning and lubrication.

Lubrication every 3,000 miles.

(a) The cam is supplied with lubricant from a felt pad contained in a pocket in the contact breaker housing. A small hole in the cam fitted with a wick, enables the oil to find its way on to the surface of the cam. Remove the contact breaker cover and turn over the engine until the hole in the cam can be clearly seen and then carefully add a few drops of thin machine oil. (The hole is located in the lowermost part of the cam ring.) Do not allow any oil to get on the contact points.

(b) The contact breaker rocker arm also requires lubrication and the complete contact breaker must be removed for this purpose. Take out the hexagon-headed screw from the centre of the contact breaker and pull the contact breaker off the tapered shaft on which it fits. Then push aside the rocker arm retaining spring, prise the rocker arm off its bearing and lightly smear the bearing with clean engine oil. When replacing the contact breaker, take care to ensure that the projecting key, on the tapered portion of the contact breaker base, engages with the keyway cut in the magneto spindle, otherwise the timing of the magneto will be upset. Tighten the hexagon-headed screw with care ; it must not be too slack, nor must undue force be used.

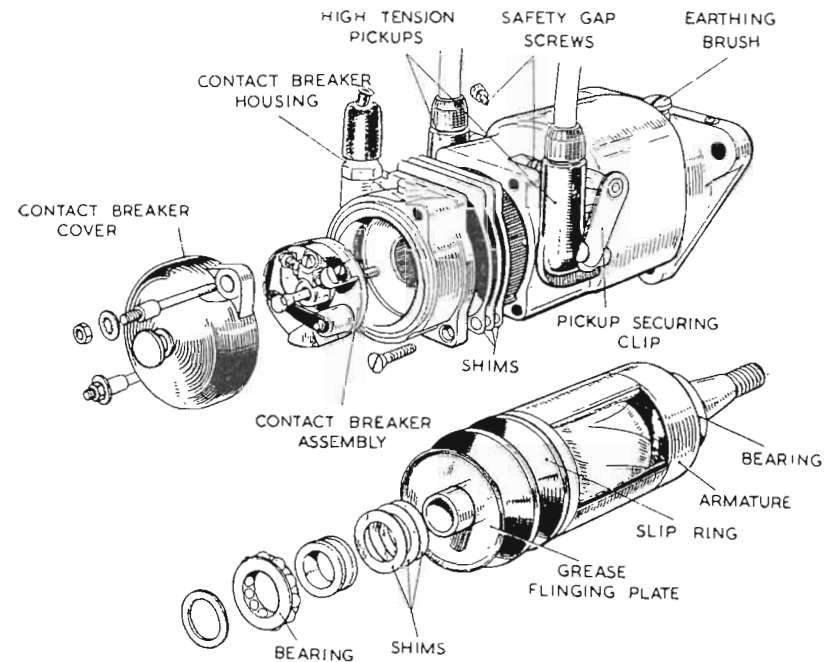

Illustration 42
Dismantled components of magneto

Adjustment every 3,000 miles

Remove the contact breaker cover and turn the engine until the contact points are fully opened. Check the gap with a gauge having a thickness of .012" (Spanner 015023 has a gauge of this thickness as an integral part of it). If the setting is correct the gauge should be a sliding fit, but if the gap varies appreciably from the gauge it should be adjusted.

Keep the engine in the position to give maximum opening of the contact points, slacken the lock nut on the fixed contact point and turn the contact screw, by its hexagon head (use spanner 015023) until the gap is set to the gauge. Finally, tighten the lock nut and re-check the setting.

Cleaning every 5,000 to 6,000 miles

Take off the contact breaker cover and remove the contact breaker. If the contact points are burned or blackened, clean them with a fine carborundum stone or with very fine emery cloth, and afterwards wipe away any dust or dirt with a petrol moistened cloth. After replacing the contact breaker check the point gap and, if necessary, re-set it.

Remove the high tension pick-ups (held by swinging spring clips), wipe clean and polish with a fine dry cloth. The high tension pick-up brush must move freely in its holder.

If it is dirty, clean with a cloth moistened with petrol. If the brush is worn to within $\frac{1}{8}$ " of the shoulder it must be renewed. Treat both pick-ups and their brushes.

While the pick-ups are removed, clean the slip ring track and flanges by holding a soft cloth on the ring by means of a suitably shaped piece of wood, while the engine is slowly turned.

If, on inspection, the high tension cable shows signs of perishing or cracking, it must be replaced by a suitable length of 7 mm. rubber covered ignition wire.

Magneto removal and fitting

The magneto is "spigot fitting" and is retained to the crankcase by two studs and one bolt.

To remove the magneto it is necessary to :

Take away the timing gear cover.

Withdraw the driving gear from the magneto shaft. (Already described in the Engine Section.)

Disconnect the high tension wires from the sparking plugs:

Disconnect the ignition control cable.

Remove the nuts from the two studs and one bolt that secure the magneto body to the crankcase and the unit is free to be taken away.

The re-fitting is done by the above procedure reversed and the method of timing has already been described in the Engine Maintenance Section.

DYNAMO

A LUCAS type E3L-L1-0 dynamo is fitted. It is anti-clockwise in rotation. The cutting in speed is 1,050—1,200 r.p.m. at 6.5 volts and at 1,850 to 2,000 revolutions per minute it gives an output of 8.5 amps at 7 volts. The positive brush is earthed. The two exterior terminals are marked "D" and "F," indicating the respective terminals for the Positive and Field wires that lead to similarly marked terminals on the Regulator Unit.

Inspect commutator and brush gear every 5,000 to 6,000 miles (Maker's Recommendation.)

Remove the cover band to inspect commutator and brush gear.

The brushes are held in contact with the commutator by means of springs. Move each brush, see they are free to slide in their holders, if dirty, or if sticking, remove and clean with a cloth moistened with petrol. Take care to replace brushes in their original positions, otherwise they will not "bed" properly on the commutator.

If, after long service, the brushes have become worn to such an extent that the brush flexible wire is exposed on the running face, or if the brushes do not make good contact with the commutator, they must be replaced by genuine LUCAS brushes.

The commutator must be free from any trace of oil or dirt and should have a highly polished appearance. Clean a dirty, or blackened, commutator by pressing a fine dry cloth against it while the engine is slowly turned over by means of the kick-starter. (It is an advantage to remove the sparking plugs before doing this.) If the commutator is very dirty, moisten the cloth with petrol.

At every 10,000 miles, the complete dynamo should be handed to a **Lucas Service Station** for dismantling, replacement of worn parts, cleaning and lubrication.

Electrical breakdown of the dynamo is most unusual and therefore before assuming this unit is defective, it should be tested as follows :

Check that the dynamo, regulator and battery are correctly connected.

Test Dynamo in position by :

- Remove the two wires from the dynamo terminals and connect the two terminals with a short length of wire.
- Start the engine and set to run at normal idling speed.
- Connect the negative lead of a moving coil voltmeter (calibrated not less than 0 to 10 volts) to either of the two dynamo terminals and connect the positive lead to a good earth point on the dynamo or engine.
- Gradually increase the engine speed, when the voltmeter reading should rapidly rise and without fluctuation.

Do not allow the voltmeter reading to rise above 10 volts.

Do not race the engine in an attempt to increase the voltage. It is sufficient to run up the engine to a speed of 1,000 r.p.m.

If the above reading is obtained the dynamo is in order.

If there is no reading, check the brush gear.

If there is a low reading of approximately $\frac{1}{2}$ volt, the field winding may be at fault.

If there is a low reading of approximately $1\frac{1}{2}$ to 2 volts, the armature winding may be at fault.

If the tests, mentioned above, clearly indicate the dynamo is not charging. It is then desirable to remove the dynamo from the machine in order to make further tests and repairs or replacements.

To remove and re-fit dynamo

The dynamo rests on a cradle forming part of the crankcase and is retained by a band having an adjustable clamping action and one stud passing through timing gear case. It is rotated by a gear meshing with the timing gear wheel on the exhaust cam shaft.

Upon merely slackening the clamping strap and removing the sleeve nut on the outside of timing cover, the dynamo, complete with its driving gear, can be withdrawn from the crankcase. The two wires from dynamo to regulator unit are retained by an insulated bridge secured by one screw and, upon removing that screw, the bridge, with the two cables, can be taken away from the dynamo.

A.V.C. UNIT

The regulator is set to maintain a pre-determined generator voltage at all speeds and regulate the output of the dynamo to the battery according to the state of charge of the battery. The charge rate is at its maximum when the battery is discharged, automatically tapering off to a minimum as the battery becomes charged and its voltage rises.

Normally, during day-time running, when the battery is in good condition, the dynamo gives only a trickle charge, so that the ammeter reading will seldom exceed 1 to 2 amperes, i.e. :—Half to one division of scale.

If, under normal running conditions, it is found that the battery is continually in a low state of charge, or is being constantly overcharged, then the regulator setting should be checked by a qualified electrician and, if necessary, re-set. Whenever possible, this should be carried out by a Lucas Service Depot or Agent.

TO REMOVE A.V.C. UNIT

The A.V.C. unit is held in sponge rubber and housed in a partition at the rear top corner of the tool box. To remove it, open the box lid, grasp the unit between the fingers and thumb of one hand, and gently and firmly pull it out. Refit with cover upwards.

The four terminals of the A.V.C. Unit are plainly marked by the letters F.A.D.E. Wires from F and D go to similarly marked terminals on the dynamo. The A terminal is connected to one of the ammeter terminals and the E terminal is "earthed."

We specially warn against unskilled meddling with the settings of the regulator and the cut-out contacts.

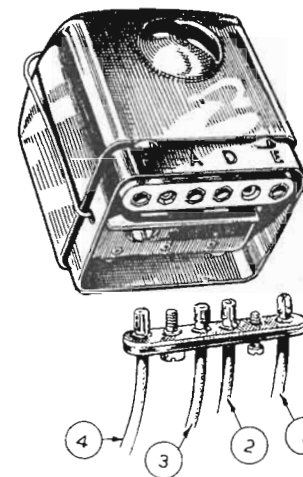

- 1 TO EARTH.
- 2 TO TERMINAL D ON DYNAMO.
- 3 TO TERMINAL 3 ON SWITCH.
- 4 TO TERMINAL F ON DYNAMO.

Illustration 43

Connections to regulator and cut-out unit

BATTERY—ALL MODELS—PUZ7E/II

A lead-acid battery LUCAS type is used on all models.

The voltage is 6, the capacity is 12 ampere hours.

Machines are issued with dry charged batteries, the acid is filled by the dealer.

All models have the POSITIVE battery terminal connected to "EARTH."

BATTERY UNIT—ALL MODELS

The battery is housed in the front portion of the tool box and retained in position on its platform by a stout rubber strap.

To remove the battery, grasp the rubber strap with the fingers between the strap and the battery case. Push the strap downwards sufficiently to release the metal toggle from the strap retaining clip. The battery can now be lifted out.

FITTING THE BATTERY

The battery **must** be inserted with the negative terminal on the right side of the battery compartment.

The specific gravity of the electrolyte indicates the state of charge of the battery. With a fully charged battery the specific gravity of the electrolyte should be 1.280 to 1.300. Check the gravity by means of a hydrometer, and if it is below 1.150 the battery should be charged as soon as possible by the normal running of the motor cycle. If this cannot be arranged, the battery should be charged from an external source.

If the level of the electrolyte is so low that a hydrometer reading cannot be taken, no attempt should be made to take a reading after adding distilled water until the battery has been on charge for at least 30 minutes.

Assuming the temperature of the electrolyte is about 60° F. a test with a hydrometer quickly shows the state of charge, as under:

- Reading 1.280 to 1.300 indicates fully charged.
- Reading about 1.210 indicates half discharged.
- Reading below 1.150 indicates fully discharged.

If the electrolyte exceeds this, .002 must be added to the hydrometer reading for each 5° F. rise to give the specific gravity at 60° F. Similarly, .002 must be subtracted from the hydrometer reading for every 5° F. below 60° F.

Topping-up the battery

During charging and normal use, water is lost by gassing and evaporation. Fortnightly, or more often in warm climates, check the electrolyte level in each of the cells and, if necessary, add distilled water. Pour the water into the flange (not down the central tube) of each correct-acid-level device until no more will drain through into the cell. This will happen when the electrolyte level reaches the bottom of the central tube and prevents further escape of air displaced by the topping-up water.

Lift the tube slightly to allow the small amount of water in the flange to drain into the cell. The electrolyte level will then be correct.

Cleaning

Keep the cell tops clean and dry.

Storage

Never leave the battery in a discharged condition. If the machine is to be out of use for a considerable period, the battery should receive a freshening charge every fortnight. Battery electrolyte, which contains sulphuric acid in a diluted form, is destructive to practically everything except rubber, lead, glass or earthenware. Therefore, rags used to clean battery tops, etc., should be thrown away afterwards. If put back in the tool box they will cause the tools to rust.

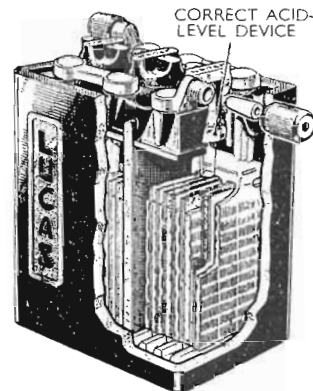

Illustration 44—Lucas Battery

SPARKING PLUG—ALL MODELS

The K.L.G. Type FE80 "Corundite" Plug is fitted to all models.

It has a thread of 14 mm. and the reach is $\frac{3}{4}$ ". The point gap is .020" to .022". Check the point gaps every time the engine is decarbonised and, if necessary, reset the points.

See that the plug is fitted with its external seating washer.

Coat the thread with "Oil Dag" or Graphite paste (see page 40).

Firmly tighten the plug by using the standard box spanner and tommy bar (Part No. 017252). All that is required is a GAS-TIGHT joint. Therefore do not over tighten, which will **not** make a gas-tight joint more gas-tight, but can, and possibly will, distort and damage the body of the plug.

Set the gaps to .020" to .022". Never try to move the central electrode. To widen or narrow the gap between the electrodes only move the earth (side electrodes). Check the gaps first with a gap gauge. If they are too wide tap the earth (side electrodes) towards the central electrode using preferably a small copper drift and light hammer. Check the gaps between each tap and stop when the gauge is a nice sliding fit between the central electrode and the three earth side electrodes.

If the gaps are too small to start with gently lever the earth electrodes away from the centre electrode using a small screw-driver and then tap them back as described above. Avoid damaging the centre electrode and do not attempt to move the electrodes apart by forcing anything between them.

For maximum efficiency, plugs should be cleaned at every 3,000 miles. To take the plug to pieces for cleaning, unscrew the gland nut by holding the smaller hexagon on the gland nut upside down in a vice and then using the box spanner to unscrew the larger hexagon on the body.

Then lift away the central electrode assembly which should be washed in petrol or paraffin. Then, using fairly coarse glass paper, remove the carbon deposit and wash again.

The central firing point should be cleaned with fine emery cloth. The inside of the body should be scraped clean with a knife and finally rinsed in petrol.

There is an internal washer, between the insulator and its seating in the body. On re-assembly lightly smear this with thin oil and then screw up the gland nut sufficiently tight to give a gas-tight joint.

Finally adjust the gap to .020" to .022".



Illustration 45

LIGHTING AND ACCESSORIES

Headlamp. Model MCH 57

A pre-focus main bulb, also a pilot bulb are mounted in the lamp reflector. The reflector and lamp glass are made up as one assembly and are not sold separately.

To remove the headlamp rim and glass, release the screw retaining the lamp rim with one hand and support the glass with the other.

The light unit can then be taken off the lamp.

To refit

Engage bottom tag on lamp rim with the small slit in the shell and gently force the top of the rim back into the shell, after which re-tighten the locking screw on the top of the lamp body.

The main bulb is secured by a bayonet fixing adaptor, which is removed with a rotary movement.

The pilot bulb is a plug-in or push fit.

The headlamp rim is detachable from the reflector and glass by removing six spring clips.

Pilot bulb	Lucas No. 988	6-volt	3-watt
Main bulb			
Home	Lucas No. 373	6-volt	30/24-watt (left-hand dip)
Export except Europe	Lucas No. 312	6-volt	30/24-watt (vertical dip)
Europe except—			
France	Lucas No. 403	6-volt	35/35-watt (Duplo)
France	Lucas No. 379	6-volt	36/36-watt (3-pin Duplo)

Setting

The headlamp should be set so that when the machine is carrying its normal load the driving beam is projected straight ahead and is parallel with the road surface.

Dipper switch

Every 5,000 miles the moving parts of the dipper switch should be lubricated with thin machine oil.

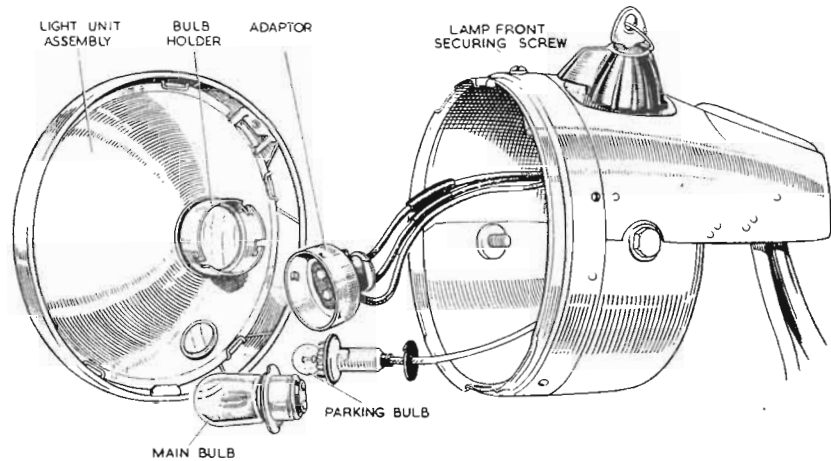

Illustration 46

LUCAS STOP TAIL LAMP, MODEL 564

The correct size of bulb to be used in rear lamps is based on the cubic capacity of the engine. The replacement bulb for this lamp is:

Lucas No. 384, 6-volt, 6/18-watt. Small bayonet cap.

LUCAS HORN, MODEL HF141

Horns are pre-set to give their best performance and, in general, no further adjustment is necessary.

If the horn becomes uncertain in its action, giving only a choking sound, or does not vibrate, it does not follow that the horn has broken down—the trouble may be due to a discharged battery, a loose connection, or short-circuit in the wiring of the horn. In particular, ascertain that the horn-push bracket is in good electrical contact with the handlebars.

It is also possible that the performance of a horn may be upset by its mounting becoming loose.

Terminals

All models have the POSITIVE battery terminal connected to "EARTH." The earth connection, for the electrical system, is connected to the frame, on top of the seat lug tube. Remove the twin seat for access.

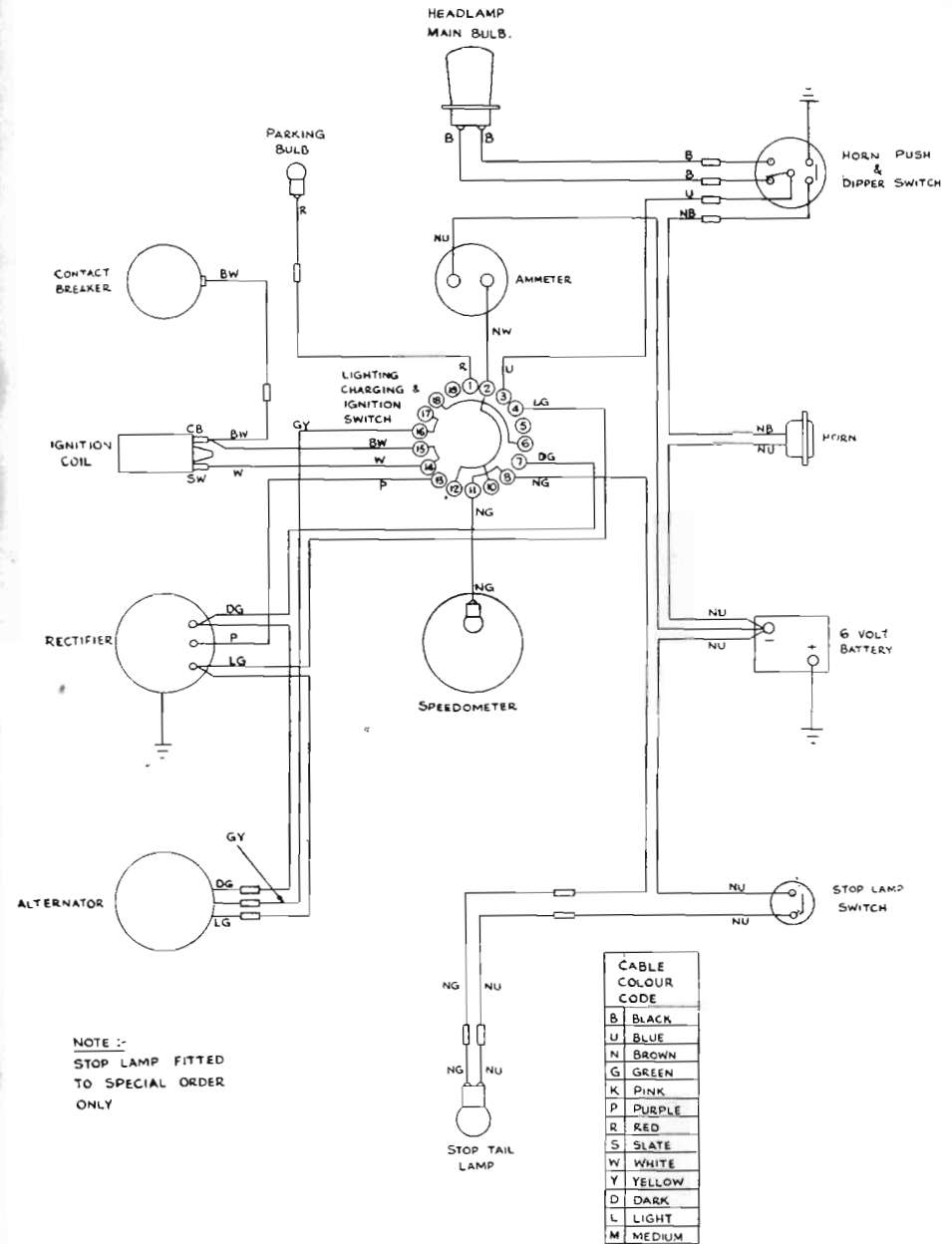

NOTE :-
STOP LAMP FITTED TO SPECIAL ORDER ONLY

Illustration 47

Wiring diagram—Singles

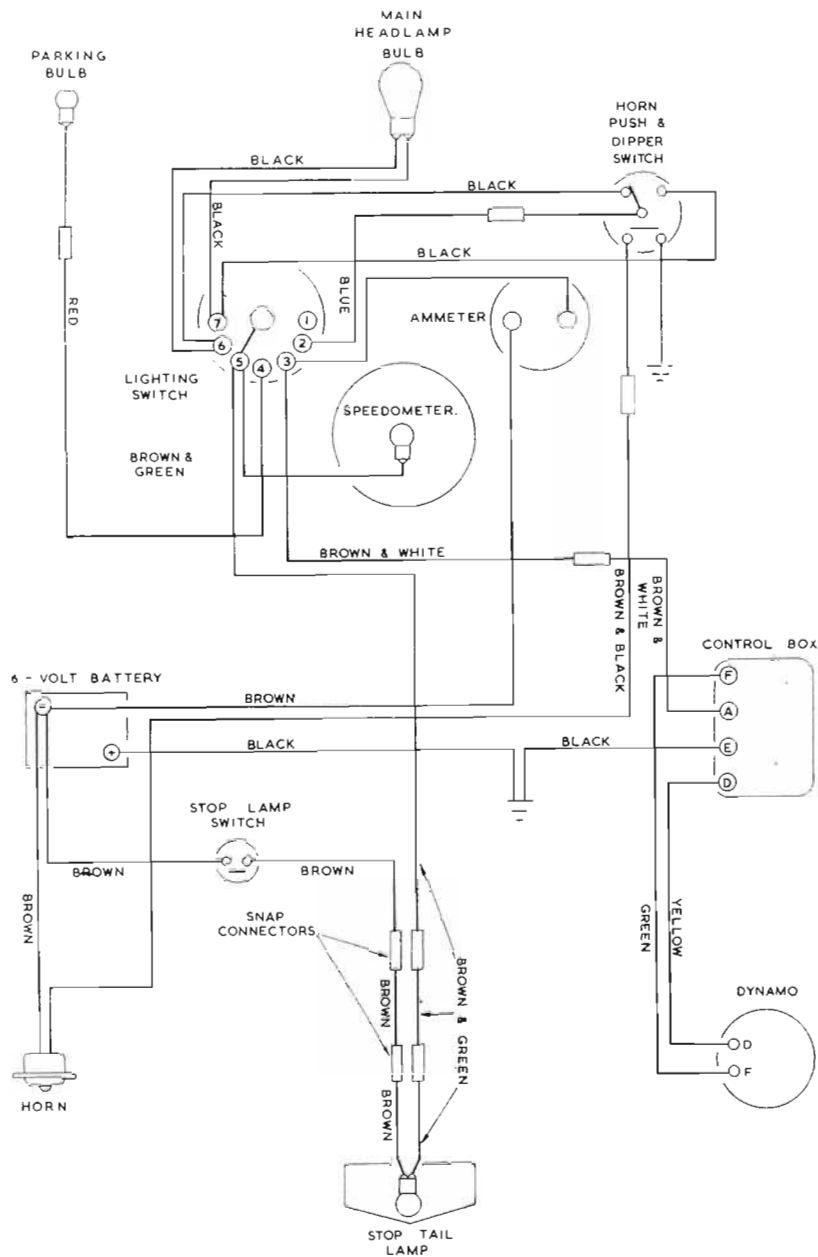

Illustration 48

Wiring diagram—Twins

USEFUL INFORMATION

In the following paragraphs are particulars of failures and troubles that can occur together with the probable reasons. These troubles are arranged in the order of their probability.

TRACING TROUBLES

Engine fails to start, or is difficult to start, may be due to :

- Water on high-tension pick-ups.
- Moisture on sparking plugs.
- Oiled up, or fouled, sparking plugs.
- Throttle opening too large.
- Pilot jet choked.
- Air lever in open position or bad air leak at carburetter joints.
- Lack of fuel because of insufficient flooding.
- Lack of fuel because of pipe, or tap, obstruction.
- Excessive flooding of carburetter (with hot engine only).
- Stuck up engine valve.
- Weak, or broken, valve spring.
- Valve not seating properly.
- Contact points dirty.
- Incorrect contact point gap.
- Ignition not switched on.
- Discharged battery.

Engine misses fire may be due to :

- Defective, or oiled, sparking plugs.
- Incorrect contact point gap.
- Contact breaker rocker arm sticking.
- Contact breaker points loose.
- Rocker adjustment incorrect.
- Oil on contact breaker points.
- Weak valve springs.
- Defective sparking plug wire.
- Partially obstructed petrol supply.
- Ignition switch at EMG.

Loss of power may be due to :

- Faulty sparking plugs.
- Lack of oil in tank.
- No rocker clearance, or too much clearance.
- Weak, or broken, valve spring.
- Sticky valve stem.
- Valve not seating properly.
- Brakes adjusted too closely.
- Badly fitting, or broken, piston rings.
- Punctured carburetter float.
- Engine carbonised.
- Choked silencer.
- Bad air leak between carburetter and head, or manifold.

Engine overheats may be due to :

Lack of proper lubrication. (Quality or quantity of oil.)
Faulty sparking plugs.
Air control to carburettor out of order.
Punctured carburettor float.
Engine carbonised.
Weak valve springs.
Pitted valve seats.
Worn piston rings.
Ignition setting incorrect.
Choked silencer.
Automatic timing control faulty.

Engine stops suddenly may be due to :

Stuck up valve.
No petrol in tank, or choked petrol supply.
Choked main jet.
Oiled up, or fouled, sparking plugs.
Water on high-tension pick-up, or sparking plugs.
Water in float chamber.
Vent hole in petrol tank filler cap choked.
Loose coil connections.

EXCESSIVE OIL CONSUMPTION

Excessive oil consumption may be due to :
Stoppage, or partial stoppage, in the pipe returning oil from the engine to the oil tank.
Badly worn, or stuck up, piston rings. (Causing high pressure in the crankcase.)
Air leak in dry sump oiling system.
Worn inlet valve stems.
Improper crankcase release valve action.

EXCESSIVE PETROL CONSUMPTION

Excessive petrol consumption may be due to :
Leaks in the petrol feed system. (Damaged fibre washers, loose union nuts on piping, defective float needle action.)
Incorrect ignition setting. (Ignition not advanced sufficiently.)
Defective engine valve action.
Incorrect use of air control lever.
Moving parts of carburettor badly worn. (Only possible after very considerable mileage.)
Bad air leak at carburettor junction, or inlet manifold joint.

STEERING UNSATISFACTORY

Incorrect steering head adjustment (too tight or excessively slack.)
Pitted steering head ball races resulting from loose adjustment.
Wheels out of alignment.
Front and/or rear tyre tread not correctly manipulated to run true with wheel (causes handlebar oscillation at low road speed).
Damaged front fork main tubes resulting from impact.

ABNORMAL TYRE WEAR

Abnormal tyre wear may be due to:
Incorrect tyre pressure.
Wheels not in alignment.
Harsh driving methods. (Misuse of acceleration and braking.)

CLEANING THE MACHINE

Do not attempt to rub, or brush, mud off the enamelled surfaces because this will soon destroy the sheen of the enamel. Mud, and other road dirt, should be soaked off with water.

The best method is to use a small hose, taking care not to direct water on to the engine, carburettor, magneto and other such parts. As a poorer substitute, a pail of water and a sponge may be used.

After washing down with water, the surplus moisture should be removed with a chamois leather, and, when the enamelled surfaces are thoroughly dry, they may be polished with a good wax polish and soft dusters.

Such parts as the engine crankcase and the gear box can be cleaned by applying paraffin with a stiff brush, and, with a final application of petrol, will come up like new.

CHROMIUM PLATING

Under some climatic conditions, a rusty looking deposit may be observed on ferrous parts that are chromium plated. This is not ordinary rust (ferric oxide) but is a salt deposit that, in most cases and in its early stages, can be quickly and easily removed with a damp chamois leather. In stubborn cases it may be necessary to use a special chromium cleaning compound.

The safest precaution during Winter is to wipe over all chromium plated parts with a soft rag soaked in "TEKALL," which is a lanoline base rust preventative marketed in small tins and available at most garages. This material, so applied, leaves an almost invisible film that is impervious to moisture and its use cannot be too highly recommended to owners who value the appearance of their mounts.

In Summer, when those conditions do not prevail, chromium parts should be frequently cleaned with a damp chamois leather and afterwards polished with a soft duster.

If a polish is used it must be one of the special compounds for chromium plating only. Ordinary metal polishing liquids, in particular, must not, on any account, be used because these, almost without exception, contain acids, which attack chromium.

NOTE—"Tekall" is a product of **20th Century Finishes Ltd., 175-177, Kirkgate, Wakefield**, and is retailed in $\frac{1}{2}$ pint and 1 pint tins. It can be obtained from our Spare Parts Department, as follows:

$\frac{1}{2}$ pint tin "Tekall," Part number 011957.

1 pint tin "Tekall," Part number 011958.

REPAIRS AND SERVICE

REPAIRS

The instructions regarding repairs should be clear and definite, otherwise the cost may be greater than that expected. We shall be pleased to give estimates for repairs if parts are sent to us for that purpose. If the estimate is accepted, no charge is made for the preliminary examination, but, should it be decided not to have the work carried out, it **MAY** be necessary to make a charge to cover the cost of whatever dismantling and re-assembly may have been done to prepare the estimate.

Customers desiring that old parts which are replaced with new during the course of overhaul or repair be retained must make the fact known prior to the work being put in hand because, normally, such parts, having no further useful life, are scrapped upon removal.

Parts sent to us as patterns, or for repair, should have attached to them a label bearing the sender's full name and address. The instructions regarding such parts should be sent under separate cover.

If it is necessary to bring a machine, or parts, to the Works for an urgent repair, **IT IS ESSENTIAL** you **MAKE AN APPOINTMENT** beforehand to **AVOID DIS-APPOINTMENT**. This can be done by letter or telephone.

CORRESPONDENCE AND ORDERS

Our routine is organised into different departments, therefore delay cannot be avoided if matters relating to more than one department are contained in one letter.

Consequently, it is desirable, when communicating with more than one department, to do so on **SEPARATE SHEETS**, each of which should bear your name and address.

When writing on a technical matter, or when ordering spares, it is essential to quote the **COMPLETE ENGINE NUMBER**. Some numbers have one, or more, letters incorporated in them and these letters **MUST BE QUOTED**, otherwise model identification is not possible.

Orders should always be sent in list form and not as part of a letter.

Owners are strongly advised to purchase a Spare Parts List so that correct part numbers can be quoted. Most parts are clearly illustrated in this list which makes it very easy to recognise the part or parts required.

PROPRIETARY FITTINGS

No expense is spared to secure and fit the most suitable, and highest quality, instruments and accessories for the standard equipment of our machines.

Nevertheless, our Guarantee does not cover such parts and, in the event of trouble being experienced, the parts in question should be returned to, and claims made, direct on the actual manufacturers who will deal with them on the terms of their respective guarantees.

Those manufacturers are :

Carburettors	Messrs. Amalgamated Carburettors Ltd., Holford Road, Witton, Birmingham, 6
Chains	The Renold and Coventry Chain Co. Ltd., Didsbury, Manchester
Electrical Equipment	Messrs. Joseph Lucas Ltd., Great King Street, Birmingham, 19
Sparkling Plugs	K.L.G. Sparking Plugs Ltd., Putney Vale, London, S.W.15
Speedometers	Messrs. S. Smith & Sons (M.A.) Ltd., Cricklewood, London
Tyres	Messrs. Dunlop Rubber Co. Ltd., Fort Dunlop, Birmingham
Rear Suspension	Girling Ltd., King's Road, Tyseley, Birmingham 11

All the above manufacturers except S. Smith & Sons (M.A.) Ltd., issue instructive literature regarding their products which is obtainable by writing to them.

SERVICE

The **Service and Repair Department** is situated in **Burrage Grove, Plumstead, London, S.E.18**, and is open on Mondays to Fridays from 8.30 a.m. to 12.55 p.m.—2.0 p.m. to 5.30 p.m. It is closed on Saturdays, Sundays and National Holidays.

It exists for the purposes of:

- Giving technical assistance verbally or through the post.
- Supplying spare parts over the counter or through the post.
- Repairing and re-conditioning machines, or parts of machines, of our make.

Burrage Grove is the first turning on the left from Burrage Road when entering Burrage Road from the Plumstead Road. (See final paragraph below.)

The nearest Railway Station is **WOOLWICH ARSENAL, SOUTHERN REGION RAILWAY**. This Station is five minutes walk from our Service Depot in Burrage Grove. There is an excellent service of electric trains from Charing Cross, Waterloo, Cannon Street and London Bridge Stations, Southern Region Railway.

Bus routes 53, 53a, 54, 99 and 122. Trolleybus routes, 696 and 698 pass the end of Burrage Road (one minute from the Service Depot).

Bus routes 21a, 75 and 161 serve **Beresford Square** which is three minutes walk from the **Service and Repair Department**.

Visitors from the North can pass into Woolwich *via* the Free Ferry between North Woolwich and Woolwich. North Woolwich is a British Railways terminus and is also served by Bus and Trolleybus routes 101, 569, 669 and 685. There is also a tunnel under the River Thames at this point for foot passengers. The Free Ferry accommodates all types of motor vehicles and there is a very frequent service. The Southern landing stage is less than a mile from the Service Depot.

Visitors arriving by road, if they are strangers to the locality, should enquire for **Beresford Square, Woolwich**. Upon arrival there, the road skirting the Royal Arsenal should be followed in an Easterly direction for about four hundred yards, and Burrage Road is the second turning on the right after leaving the Square. Burrage Grove is then the first turning on the left.

THE DRIVER AND THE LAW

The driver of a motor cycle **MUST** be **INSURED** against Third Party Claims and **MUST** be able to produce an **INSURANCE CERTIFICATE** showing that such an insurance is in force.

If your Insurance Certificate specifies you can only drive one particular machine you **MUST NOT DRIVE** any other machine unless its owner has a current Certificate covering "**ANY DRIVER**" and it is advisable to remember that, in the absence of such a provision the penalties for doing so are very heavy.

The driver of a motor cycle **MUST** hold a current **DRIVING LICENCE**. If you are a learner and hold a Provisional Driving Licence, your machine must show, front and back, the standard "L" plates in red and white and you must not take a **PILLION PASSENGER** unless that passenger is the holder of a current **UNRESTRICTED** driving licence.

As soon as you receive your driving licence, sign it in the appropriate place and do so each time it is renewed. It is an offence not to.

Make sure you are well acquainted with the recommendations set down in the "Highway Code," a copy of which can be obtained from any main Post Office.

THE MACHINE AND THE LAW

Every motor cycle used on the public roads must be registered and carry the registration numbers and licence disc allotted to it. The dealer, from whom the machine is bought, will, generally, attend to all matters legally essential before it is used on the public roads.

To register a new machine :

Send to the Local Registration Authority the following:

- (a) Form "RF1/2," duly completed.
- (b) The certificate of insurance.
- (c) The invoice you received from your dealer when you purchased the machine.
- (d) The appropriate registration fee.

In due course you will receive:

- (1) A Registration Book. (Commonly called the "log" book.)
- (2) A Licence Disc.
- (3) Your Insurance Certificate.
- (4) Your Invoice.

The Registration Book and the Licence Disc will bear the registration numbers that have been allotted to your machine and will also show the date the Road Licence expires.

Your number plates must then be painted, in white upon a black background, with the registration numbers in characters of even thickness as follows:

The numbers on the front plate must be $1\frac{3}{4}$ " high, $1\frac{1}{4}$ " wide and $\frac{5}{16}$ " thick with spaces of $\frac{1}{2}$ " between each two characters.

The numbers on the rear plate must be $2\frac{1}{2}$ " high, $1\frac{3}{4}$ " wide and $\frac{3}{8}$ " thick with spaces $\frac{1}{2}$ " between each two characters.

The Licence Disc must be enclosed in a water-tight container, having a transparent front, and this must be fixed to the machine in a conspicuous position, near the front and on the left-hand side.

It is not legally necessary to carry your Driving Licence, Insurance Certificate and Registration Book while driving your machine.

Ignition Suppressors

As required by law all 1958 models for the Home Market are issued with an approved type of radio interference suppressor already installed.

Speedometer

A speedometer **MUST** be fitted and it **MUST BE** so **ILLUMINATED** that it is possible to read the dial after lighting up time.

Lamps

During the official "**LIGHTING UP**" hours the machine must exhibit a white light facing forwards and a red light facing rearwards. The rear number plate must be adequately illuminated by a white light.

Each front electric light bulb **MUST** be marked with its "Wattage." (Beware of cheap, imported, bulbs that do not have this marking.)

All motor cycles made by us have electric equipment that complies with the law regarding position, size of bulbs, marking on bulbs and the correct illumination of the rear number plate.

FREE SERVICE SCHEME

FREE SERVICE SCHEME

All owners of **NEW MODELS** are entitled to one **FREE SERVICE AND INSPECTION** at 500 miles, or, at latest, three months after taking delivery.

This service is arranged by the supplying dealer to whom the **Free Service Voucher** must be handed. This voucher, together with the Instruction Manual, are supplied by us upon receipt of the signed application card to be found in the tool box upon taking delivery of a new motor cycle.

The **INSPECTION AND SERVICE** consists of:

(a) Check, and, if necessary, adjust:

- | | |
|-----------------------------|------------------------------|
| (1) Rocker clearances. | (6) Wheel bearings. |
| (2) Contact breaker points. | (7) Brakes. |
| (3) Sparking plugs. | (8) Forks and steering head. |
| (4) Clutch. | (9) Alignment of wheels. |
| (5) Chains. | (10) Tyre pressures. |

(b) Tighten all external nuts and bolts, including cylinder head nuts and fork crown pinch screws.

(c) Top-up battery and check all lighting equipment.

(d) Clean out carburetter and check for correct idling.

(e) Adjust all cables.

(f) Grease all nipples.

(g) Drain oil system. Clean filter and replenish.

(h) Check oil level in front chaincase.

(i) Top-up gear box.

(j) Test machine on the road.

NOTE—Oils, greases and materials used are chargeable to the customer.

FOR THE CONVENIENCE OF OWNERS, SPARES STOCKISTS

ARE APPOINTED FOR MOST DISTRICTS. TO SAVE DELAY, AND THE DELIVERY SURCHARGE CUSTOMERS ARE RECOMMENDED TO ALWAYS APPLY TO THEIR NEAREST SPARES STOCKIST.

SPARE PARTS

GENUINE SPARE PARTS purchased from an Authorised Dealer, or from the Factory, are identical with the parts originally built into your motor cycle. By using them you are assured that they will fit accurately and give satisfactory service.

SPARES STOCKISTS

For the convenience of owners Spares Stockists are appointed for most districts. To prevent delay and save the delivery surcharge, customers are recommended always to apply to their nearest Spares Stockist.

CORRESPONDENCE AND SPARES ORDERS

Always quote the complete engine number, including all the letters in it. This will enable us to identify the machine.

Each series of frames is numbered from zero upwards, therefore, the quotation of a frame number only does not facilitate identification.

SPARES LIST

An illustrated spares list covering the models described in this Instruction Book is available on application. Price 3s. 6d. each.

PART NUMBERS

If there is any doubt about the names of parts required, or their part numbers, please send the old parts as patterns.

REMINDER

Do not forget to include your name and full postal address. We do receive orders without this very necessary information.

PAYMENT

- (1) Cash with order.*
- (2) Cash against pro-forma invoice.
- (3) Approved ledger account.

We do not send C.O.D. (Cash on delivery).

*Add 5% of total value for carriage and packing. Minimum 1/-.

GUARANTEE

Full details of the guarantee relating to the models described in this book are given on page 97.

INSTRUCTION BOOKS

A copy of this book is issued free of charge to all purchasers of a new machine.

TOOLS AND SPECIAL EQUIPMENT

TOOLS

The standard tool kit, issued with each new machine, contains:

1	017253	Tool bag.
1	017114	Tyre inflator.
2	017007	Tyre lever.
1	017248	Pliers.
1	011188	Gudgeon pin circlip pliers.
1	017256	Screwdriver.
1	017246	Grease gun.
1	017249	Adjustable wrench.
1	017252	Sparking plug box spanner and tommy bar.
1	018178	Spanner 1-010" and 1-200".
1	017052	Double end spanner, $\frac{3}{16}$ " \times $\frac{1}{4}$ ". (Singles 2 off)
1	017053	Double end spanner, $\frac{5}{16}$ " \times $\frac{3}{8}$ ".
1	015023	Contact point spanner and gauge.
1	018055	Key, for handlebar clip screw and rocker cover bolts.
1	017257	Double end spanner, $\frac{3}{16}$ " \times .375".
1	015264	S.E. spanner. (Rocker clamping bolt nut.) Twins only.
1	015213	Box spanner. Twins only.
1	017254	Clutch spring stud nut adjuster.
1	018667	Key for fork crown pinch screw.
1	023284	Spanner for suspension unit.
8	000174	Brake shoe thrust washers.

OPTIONAL EQUIPMENT

The following items of optional equipment are available. They are described and priced in the Spares List.

Stop rear light.

Air cleaner.

Gear extractor 015374. A bridge type extractor, consisting of bridge, central screw and two side bolts, for removing the gears on the camshafts. (Twins)

Detachable luggage carrier.

Timing disc 022011. A circular timing disc, graduated in degrees and made of ivory. A very useful device.

Pinion extractor 015273. A two-piece extractor for removing the timing gear small pinion and the gear on the magneto shaft. (Twins)

Pannier frames and bags.

Holder for valve grinding. Part number 011381 Twins, 017482 Singles.♥

Pillion footrests, specially designed fold up type.

Crash Bar sets.

Valve spring compressor. Part number 018276. (Singles)

GASKET SETS

For convenience in ordering, standard sets of engine washers and gaskets are stocked. Full details of contents and prices are included in the Spares List.

BADGES

Neat monogram badges are now available at a cost of 1/6, plus 6d. postage. They can be supplied as a brooch or for fitting in a button hole. When ordering state type required.

	Page
...	91
...	83
removal ..	40
lubrication ...	25
.. ..	11
es of unsatisfactory	88
adjustment ...	58
lubrication ...	25
... ..	12
critical equipment...	84
removal	44
kit	95
les	87
justment	46
... ..	72
... ..	88
3	34-41
removal	32-41
l	32-41
... ..	36-43
g adjustment ...	66
g, front	67
g, rear	68
al, front	66
al, rear	66