



THE SMITH INSTRUMENT INSTRUCTION BOOK

S. SMITH & SONS (M.A.) Ltd.
Cricklewood Works, London, N.W.2.

Telephone: Willesden 2335-6-7.

Telegrams: Speedofac, Phone, London.

Show Rooms: Speedometer House,
179/185, Great Portland Street, London, W.1.
Phone: Langham 2323. Tel.: Speedomet. Telev. London.

HOME SERVICE DEPOTS:

Midland Service Depot: 122, Alma Street, Birmingham.
Northern Service Depot: 12, Jackson's Row, Manchester.
Scottish Service Depot: 23/25, Renfrew Street, Glasgow.
Irish Service Depot: 39, Donegal Street, Belfast.

FOREIGN & COLONIAL BRANCHES:

New York, Buenos Aires, Paris, The Hague, Milan, Cape
Town, Sydney, Wellington, Bangkok and Sourabaya.

THE SMITH Instrument Instruction Book.

INTRODUCTION

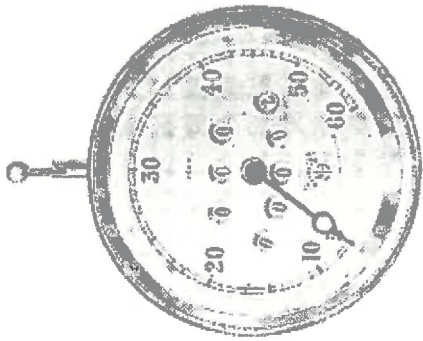

Figure 1.— Type No. AA1.
The Smith British Speedometer. (Flush Fitting Model).

The season of 1919-1920 will always be regarded as the period in which the Smith British Speedometer gained its highest and its proper place in the Motor World, a model of one type or another being fitted by practically every car manufacturer, and included as part of the standard equipment with his car.

It seems strange indeed that any single motorist can possibly do without a Speedometer, for it is such a trusty "companion of the road"—it tells you how fast you go, how far you go, the lengths of the stages of your journey, and gives you a basis for finding your petrol consumption in miles per gallon.

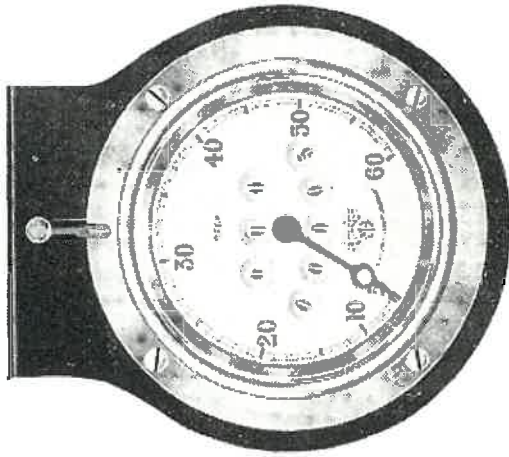

Figure 2.— Type No. AA21.
The Smith British Speedometer. (Semi-Flush Bracket Model).

In presenting this little book, it is generally assumed that the reader will already have made his selection from our catalogue and that the matter herein will assist him in fitting up or taking care of his instruments.

Before going on with a brief résumé of types, we should like to say that our Speedometer and Revolution Indicator are of the centrifugal governor type, this being the most accurate speed indicating mechanism yet designed, as was proved during the War, when we made some thousands of Revolution Indicators for Aeroplanes.

THE SMITH SPEEDOMETERS

Smith's post-war Speedometers are manufactured in two grades or types, *i.e.*, the standard model, known as the "British Type," and the high-grade model, known as the "De Luxe Type."

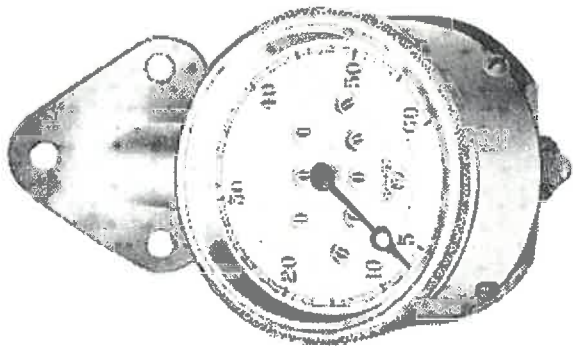

Figure 3.— Type No. AA11,
The Smith British Speedometer. (Bracket Model).

The principal types of the Standard or British Models are :—

- Type AA1. Flush fitting model ... (Fig. 1)
- Type AA21. Semi-Flush Bracket model ... (Fig. 2)
- Type AA11. Bracket model ... (Fig. 3)
- Type AA166. Commercial Speedometers and Mileage Recorder (Fig. 4)
- Type AA191. For Motor Cycles ... (Fig. 5)

We make a similar range of instruments in the De Luxe models, but we propose to illustrate here only the De Luxe Flush-fitting Speedometer, type AA31 (Fig. 6), as fitting instructions would be the same for Standard or De Luxe types.

The functions of all the post-war types of Speedometers, as marked above, would be as follows :—

1. The pointer records the speed and will be found to answer accurately and immediately to all changes in progression of the car.

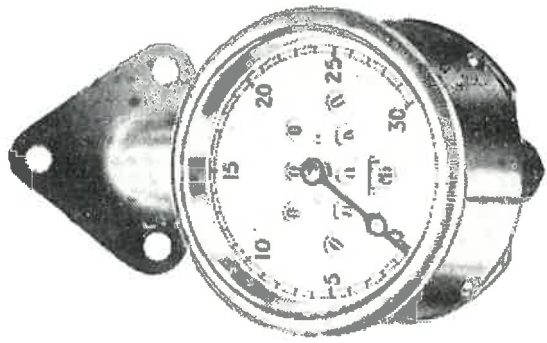

Figure 4.— Type No. AA166,
The Smith Combined Speedometer and Mileage Recorder.

2. The bottom or curved row of figures indicate the total distance up to 10,000, when they automatically return to 0's, thus record 10,000 as well as zero for a new start.



Figure 5.— Type No. AA191,
The Smith Motor-Cycle Speedometer.

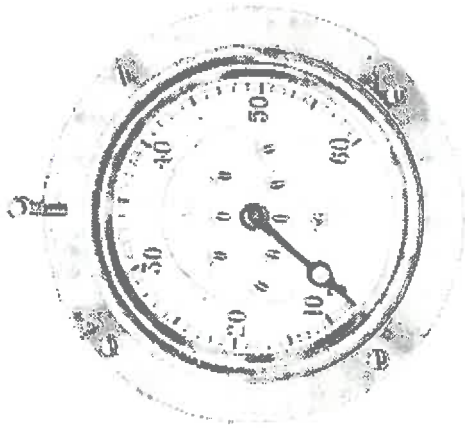

Figure 6. — Type AA31.
The Smith De Luxe Speedometer. (Flush-Fitting Model).

3. The top row of figures record the trip, the first figure indicates tenths of miles.

These figures are set to 0 by depressing the lever or knob at the top of the case.

Any of our Speedometers can be supplied with speed dials up to 60, 80, or 100 miles. Kilometre Instruments can be supplied to order.

REVOLUTION INDICATORS

We can supply engine Revolution Indicators to absolutely match up to any of our standard British or standard De Luxe Speedometers. Attachment instructions for fitting this instrument to the dashboard would be the same as for Speedometers. See Catalogue for various types.

Unless special arrangements are made by Car manufacturers, Revolution Indicators are generally driven from the clutch shaft, or from the magneto or dynamo coupling, and we can supply special drives for new type Crossley, Vauxhall, A.B.C. Austin, etc., etc.

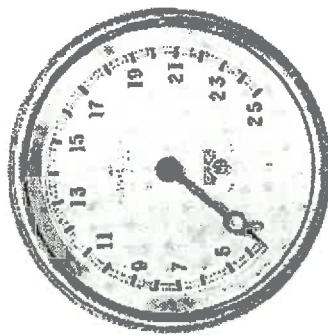

Figure 7. — Type No. AA61.
The Smith Engine Revolution Indicator.

Where the drive has to be arranged from the clutch shaft, it is often found necessary to supply a special narrow driving pulley, owing to limited space.

Fitting instructions for this type of drive would be covered by instructions for fitting Cardan Drive for Speedometer.

For this particular drive we require to know— diameter of the clutch shaft; amount available for pulley, after having made allowance for all the movements of the clutch parts; and length of flexible shafting.

Many manufacturers of Cars provide a special drive for the Revolution Indicator even when not fitting same as a standard. This is generally adapted from the end of the cam shaft, and in this case we require to know—the relative speed of the drive to the engine; details of the drive fitting and length of flexible shafting.

Before ordering a Revolution Indicator it is, in most cases, best to communicate with the Car manufacturers to ascertain if anything in the nature of the fitting has been embodied in the engine.

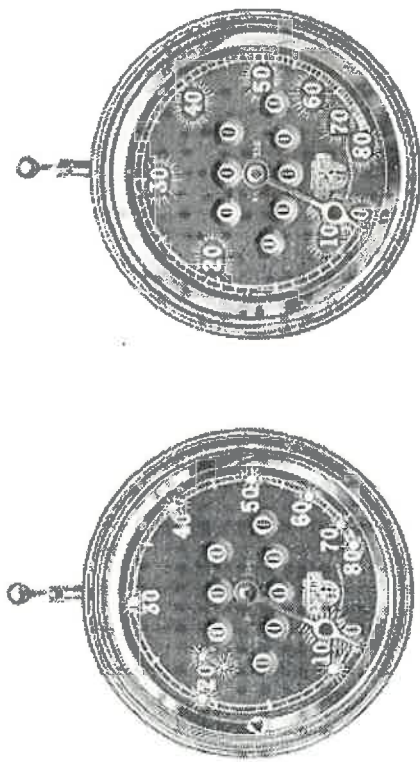

Figure 8.
The Smith British Speedometer (Luminous Dials).

Our Catalogue gives full particulars of the various instruments we make to match up with the Speedometers, and which in brief are:—
Motor Clocks.

Aneroids and Altitude Recorders.

Our famous Bezel Lighting Switch.

Gauges—for Fuel, Oil and Tank Capacity.

Another refinement we are giving careful attention to is the luminous dial—either by whole figures or dots (as above)—whereby the functions of any of the instruments can be seen easily at night.

ATTACHMENT INSTRUCTIONS

TYPE A-1 STANDARD FLUSH FITTING. — This model has been designed to give a perfectly neat and efficient flush fitment, with the idea that as little metal as possible should be visible, and, further, with the intention of cutting out unnecessary cleaning and polishing. An opening should

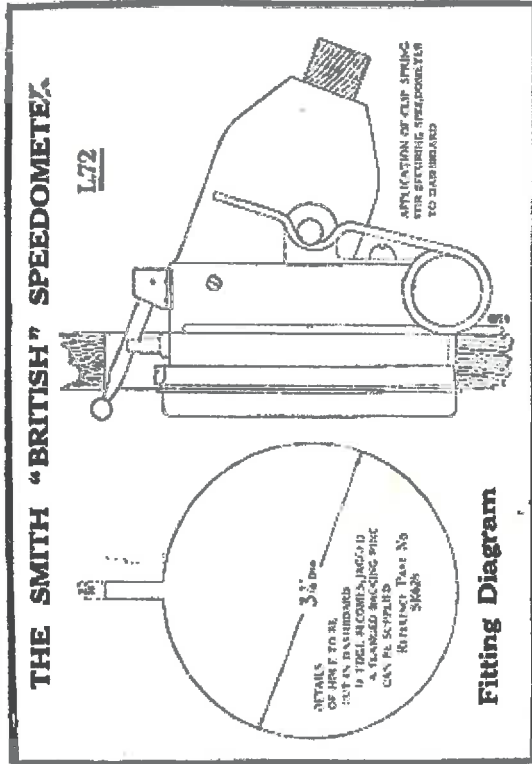

Figure 9.
The Smith British Speedometer.

be cut in the instrument board, as shown on diagram (page 9); the instrument is then placed into the opening from the front, and a spring fitting applied, as shown. It will be seen that the spring pulls the Speedometer against the front of the instrument board, and it is only necessary to make sure that the two wires are well under the heads of the studs on the bracket piece secured to the back of the Speedometer. This special spring takes up practically any thickness of board, and will securely hold the instrument against vibration.

If owing to limited space, or to the fact that the back of the instrument board is not accessible, the spring cannot be fitted, we can supply you with a loose ring (our part No. S.K. 4147), which is simply placed over the head on the Speedometer case, and held to the instrument board by four No. 4 x 1/4" raised head wood screws.

TYPE AA31 DE LUXE FLUSH FITTING. -- The De Luxe Flush Fitting Speedometer is attached to the instrument board by four No. 4 x $\frac{1}{2}$ " raised head screws in the flange holes.

Blue Print Diagrams at the end of this book clearly show fitting of De Luxe and Standard Flush Speedometer as per instructions above, and also space behind board required.

In cleaning the flush type instruments, the instrument board may be kept free from scratches and marks if a piece of cardboard cut with a hole the size of the Speedometer bezel is placed over the bezel while the latter is being rubbed up.

SEMI-FLUSH STANDARD AND DE LUXE INSTRUMENTS ON BRACKETS (similar to Fig. 2). -- The instrument itself must be taken out of the bracket by removing the four screws in the flange--access will be gained to the back of the bracket through the front opening, and the bracket can be attached to the dashboard by three wood screws or bolts and nuts. The instrument flanges and its four screws must then be replaced. Tighten the screws well, and do not let your screw-driver slip.

DASHBOARD TYPES (similar to Fig. 3).--In these types the bracket has to be attached to the dashboard by three screws, in which case a fairly strong round-head screw should be used, or the bracket can be secured by $\frac{3}{8}$ " Whitworth bolts and nuts; the latter, however, are rather clumsy. Care should of course be taken to fix the indicator in the most advantageous position for the driver, and with due regard for the lead of the flexible shafting to the drive (see Drive Instructions).

MOTOR CYCLE TYPE. -- This type should be attached to the handle-bar in such a position that

all the functions of the Speedometer are clearly visible to the driver, and with consideration to the lead of the flexible shafting, which should lead out towards the front of the mudguard, and then up to the handle bar, so as to form a bend in which the springing action of the forks cannot strain the flexible shafting; if it is required to fit a $\frac{1}{8}$ " bar a piece of $\frac{1}{16}$ " thick fibre should be used to pack up the difference.

GENERAL REMARKS

The following general remarks may be noted:--

The Speedometer itself need not be lubricated, as the ball races and frictional parts have been designed to retain the lubricant necessary up to the time when the instrument should be thoroughly cleaned and overhauled to keep it in perfect condition; normally, this overhaul should be done every two or three years.

Every Smith Speedometer can be run either clockwise or anti-clockwise, and in every case the mileage mechanism will add.

Should any derangement take place, the instrument should be sent back to the maker, and repairs will be put through at the lowest possible cost.

METHODS OF DRIVING SPEEDOMETERS

Most of the leading manufacturers of cars now embody a Speedometer drive in the design of the car. This drive is usually adapted to the gear

box. This is, of course, the most satisfactory method of driving a Speedometer, but can only be arranged for by the foresight of the car manufacturer who has given some thought to the Speedometer drive.

When special drives are not supplied in the design of the car, and the cardan shaft is open, i.e., not closed in a torque tube, we strongly recommend our standard cardan shaft drive (see

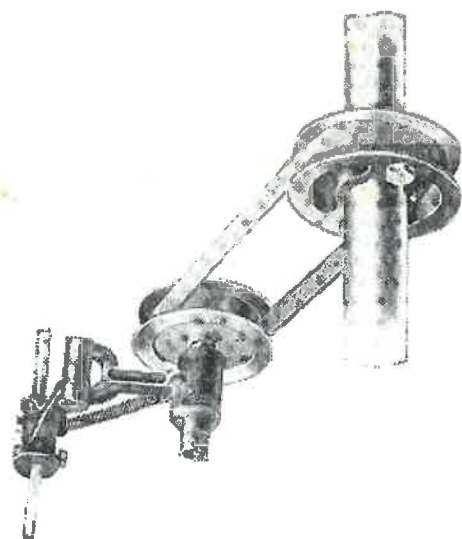

Figure 10. Type No. AA181. The Smith Cardan Shaft Drive.

Fig. 10). The Smith Cardan Shaft Drive, or Live Axle Drive, has proved to be by far the most satisfactory method of transmission that can be applied to a car, apart from the special drives embodied in the design of the car; being solidly made it is very sound and efficient, silent in its operation and easy to fit.

For this drive we require to know gear ratio from the back axle (D & E), diameter of cardan

shaft, and running radius of back tyres (see diagram, Fig. 20, on page 28), also size of tyre as stamped thereon.

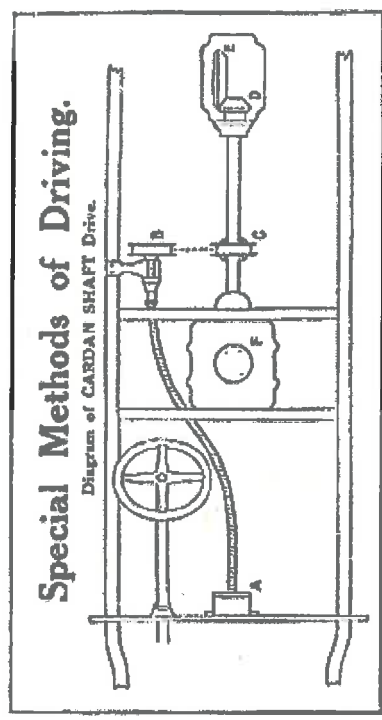

Figure 11.

Several makes of cars which have the cardan shaft enclosed, or partly enclosed, can be fitted with special live axle drives, and we may mention Albion, De Dion, Talbot, Gregoire, Renault, etc. This remark refers to pre-war models, as well as post-war models of cars.

Again, some cars with enclosed cardan shafts have a special driving pulley embodied on the universal joint cover or brake drum, and consequently a belt drive can be easily fitted. Noted instances of this type are the new Crossley, Gregoire-Campbell, Daimler, etc.

The Cardan Drive can also be adapted to the sprocket shaft of chain-driven cars or to any exposed live axle, and is also suitable for motor boats, factory and experimental plant, or, in fact, for any purpose where speed-indicating mechanism is required to be driven.

FITTING INSTRUCTIONS FOR THE SMITH CARDAN SHAFT DRIVE

Attach the split pulley to the Cardan Shaft as near the gear box as it can conveniently be fitted, making sure the nuts are well tightened and that spring washers are under each nut.

The bracket arm carrying the driven or solid pulley should be affixed to the frame by the two set screws. It is an advantage to slightly counter-sink the frame so that the points of the set screws get a better grip. This counter-sinking can be done by $\frac{1}{4}$ " drill and need not be more than just a mark—say, about $\frac{1}{32}$ " deep. The bracket arm can be held by one set screw while the other is being marked off, each set screw being removed in turn so that the drill can be entered and used in its place.

This particular type of grip fitting has been designed to meet the demand for a fitting that can be attached without drilling the chassis.

Some customers, however, still prefer to drill the chassis and fit bolts and nuts as was the old practice. We have therefore arranged for the two holes in the bracket to go right through, so that $2" \times \frac{1}{4}"$ bolts and nuts can be used for securing the bracket to the chassis. In this case, $\frac{1}{4}"$ holes should be drilled in the chassis.

In fitting the Cardan arm to the chassis, care should be taken to see that the brake rods, etc., do not foul the bracket; they should in fact have some clearance so that under vibration of driving no noise or rattling takes place.

The pulleys should be carefully set in line and the bracket arm should be given a "set" so that the two pulleys are in the same plane; this will, of course, be governed by the tilt of the Cardan Shaft (see diagram, Fig. 12).

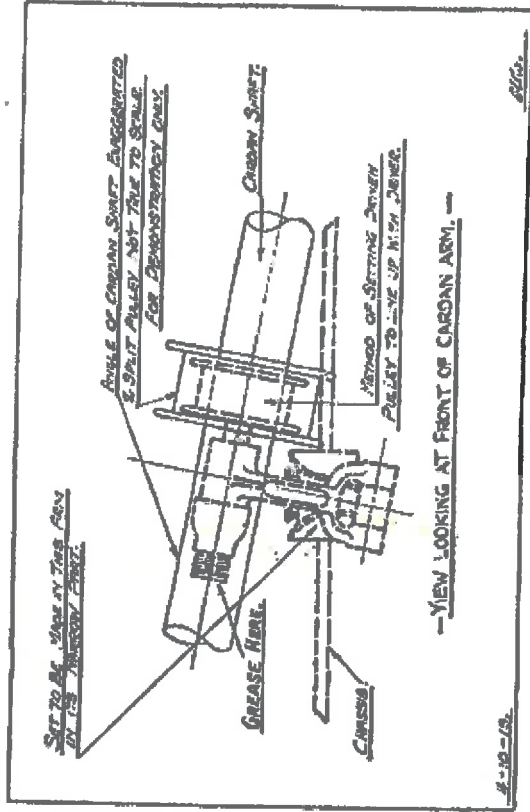

Figure 12

This detail is most important, as the accurate "lineing" of the pulleys ensures long life to the belt.

For Cardan Drive it is immaterial to which side of chassis attachment is fitted, but it will generally be found more convenient on off-side.

The drive should be so arranged that the belt is as near as possible parallel to the ground, so that the up and down movement of the Cardan shaft cannot tug at the Speedometer belt.

We illustrate two suggested methods of joining a belt figures 13 and 13a, and instructions for joining are as following:—

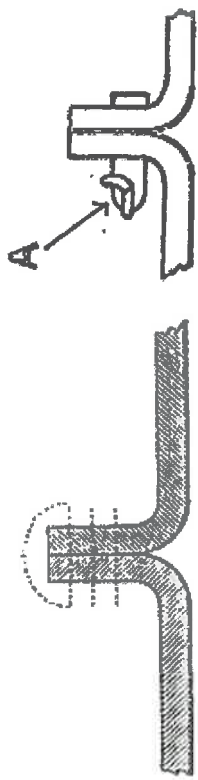

Figure 13.

FIGURE 13. Bring the two ends of the belt up and away from the Driving Line and stitch firmly "over and through" with shoemaker's wax ends.

FIGURE 13a. To fit Belt Fastener, pierce each end of Belt for the staple with an awl (or pen knife). Bring the ends together and drive staple home (a block should be interposed between hammer and staple, to avoid damaging the latter). Insert roller and split pin and turn the split pin ends well back in the direction shown at "A" above.

The tension on belt is effected by suspending a coil spring from hole in pulley-arm to hole in bracket arm. For necessary tension, stretch the spring to about $1\frac{1}{2}$ times its idle length.

For Cardan Drive each set is made to gear ratio (crown and bevel of cardan or chain wheels of sprocket drive) and diameter of back tyres, and if, owing to wrong ratio or tyre size having been given to us, there is a slight error when tested to measured distance, a percentage turned off either pulley (as the case may require) equal to percentage of error will give an exact adjustment.

If Speed Indicator records too fast, turn split pulley smaller; if too slow, turn solid pulley smaller.

Should error be too great to alter in this way, or should same be inconvenient, a correct size

pulley will be forwarded on receipt of old pulley, and advice as to percentage of error.

CARDAN SHAFT LUBRICATION.—The cardan arm bearing is packed up with grease when assembled, which should last at least 15,000 to 20,000 miles. It can, however, be easily relubricated by unscrewing the double casing union and forcing two or three thin rods of grease, such as Prices' Belmo-line, into the top of the conical cap.

(See page 25 *re* Flexible Shafting Lubrication Instructions and Attachment.)

METHOD OF ASCERTAINING CORRECT SIZE OF PULLEYS FOR CARDAN SHAFT DRIVE

The driving or split pulley which is attached to the Cardan Shaft is generally either 84 or 66 m.m. diameter over the belt way.

The size of the driven or solid pulley is obtained by the following formula:—

R. Revolutions of tyre per mile (see schedule on page 29) and diagram (half wheel, Fig. 20).

C. Split pulley diameter—say, 84m/m.

D. No. of teeth on bevel pinion or worm.

E. No. of teeth on bevel wheel or worm wheel.
Multiply R x C x E and divide by 3,360 multiplied by D.

Two examples as follows:—

(1) Tyres 880 (610 revs. per mile, see schedule, page 29), Gear Ratio 16/60, *i.e.*, 16 on bevel pinion.

60 on Bevel wheel. Cardan Shaft $1\frac{5}{16}$ "
 Tyre revs. per mile. Split Pulley. Bevel Wheel.

610	84	60
3,360	1	16

Speedo. revs. per mile. Bevel Pinion.
 Result :— 57 solid pulley.

84 split pulley with $1\frac{1}{8}$ " bore.

(2) Tyres 810 (660 revs. per mile, see schedule, page 29), Gear Ratio 8/32, i.e., worm of 8 teeth, worm wheel of 32 teeth. Cardan Shaft $1\frac{3}{8}$ ".

Tyre revs. per mile. Split Pulley. Worm Wheel

660	84	32
3,360	1	8

Speedo. revs. per mile. Worm.

Result :— 66 solid pulley.

84 split pulley with $1\frac{3}{8}$ " bore.

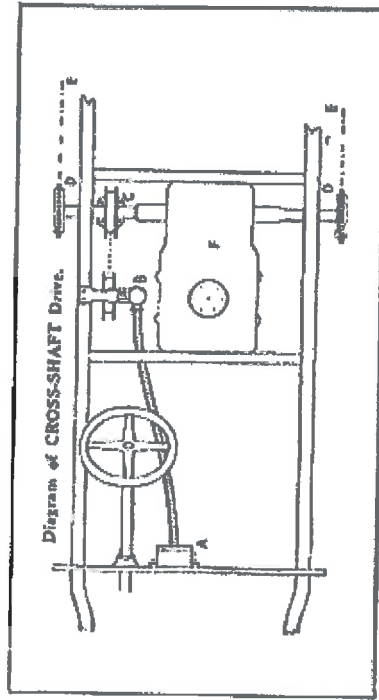

Figure 14.

CROSS SHAFT DRIVE

A very efficient Drive for chain-driven Cars—we supply a pulley without lugs, thereby necessitating only a short piece of the shaft being exposed.

This Drive is applicable to most commercial Cars, and where it is not possible to attach, we can in most cases supply special pulleys to attach to the sprocket wheels or gear box brake drum.

For this Drive we require to know—number of teeth on chain wheels (D & E), diameter of cross shaft, and running radius of back tyres (see Fig. 20), also size of tyre as stamped thereon.

We make a special feature of designs to meet individual requirements.

Cardan Drive fitting instructions apply generally to this drive.

THE SMITH SPEEDOMETER GEAR DRIVE (For Front Wheel Fitting)

This very practical Drive is very strongly recommended, and is particularly adaptable where the Cardan Shaft of the Car is enclosed, and where large stocks of Speedometers for quick fitting are carried. The casing is of Phosphor Bronze, and the interior spiral wheels highly finished hardened steel.

For this Drive we require to know size of front tyres, diameter of hub flange and length of flexible shafting.

FITTING INSTRUCTIONS FOR FRONT WHEEL CAR GEAR DRIVE

The off-side front wheel (preferably) should be taken off, and the large wheel marked "A" on above illustration attached concentrically on the

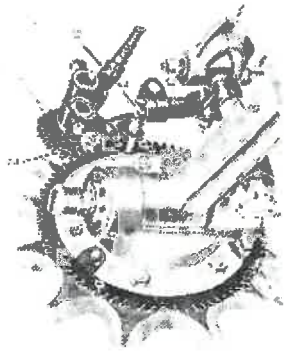

Figure 13.—Type No. AA183.
The Smith Gear Drive.

inside. It will be noticed that gear rings are drilled so that they can be screwed to each alternate spoke, either with wheels of 10 or 12 spokes. It is, of course, necessary that this wheel should be absolutely concentric.

In some cases it is an advantage to make the gear ring stand away from the spokes, and this can be done by using washers about $\frac{3}{16}$ " thick, ordinary nuts with the screw holes sufficiently large to go over the fixing screws will serve the same purpose. If fitting to wood spokes use $1\frac{1}{4}$ " by No. 9 wood screws.

The bracket clamp "B" holding bracket "C" should now be placed in position, and by loosening set screw "D" and nut at end of the bolt "E," the pinion "F" can be brought into proper mesh with the gear ring "A," and the whole fitment can be so arranged that the flexible shafting gets its proper lead towards the instrument.

The road wheel should then be spun before finally tightening up set screw "D" and nut at end of the bolt "E" before finally replacing the wheel to the car.

The flexible shafting and casing can then be attached to the end of the shaft "G," next attach the flexible shafting and casing to the instrument head in the same way (see page 25 *re* Instructions for Attaching Shafting).

Before taking the jack from the axle, it would be as well to spin the wheel to see if everything is in proper order, and the gears in proper mesh. Also carefully observe if the steering can be moved in both directions to their furthest limits so as to make sure that everything is clear.

The nuts should then be finally tightened up, and the flexible shafting made to strap to a convenient part of the chassis, taking care that there is enough slack to allow for the full steering movement of the Car, without causing sharp bends of flexible shafting.

The Gear Drive suitable for a given tyre size is based on number of teeth on gear ring. Tyres vary so much between their actual running radius and the given size thereon, that without actually measuring the tyre under running conditions it is somewhat difficult to give correct size ring. Generally, three or four teeth on ring above the first two figures of stamped tyre size give an accurate reading, *i.e.*, for 810 or 815 tyre-fit 84-tooth ring, for 880 fit 91, and for 920 fit 95, etc.

FRONT WHEEL DRIVE LUBRICATION. — The grease cap near the top of the gear box should be refilled with grease every 1,000 to 1,500 miles. Good thin grease such as Prices' "Belmoline" should be used.

(See page 25 *re* Flexible Shafting Lubrication and Attachment Instructions.)

DETACHABLE WHEELS

Detachable wheels very often cause a good deal of trouble in fitting speedometers. It is obvious that if the gear wheel is attached to the spokes of the wheel, either wood or wire, the speedometer would be out of action if the wheel is removed to change. It is therefore advisable to fit the spur gear wheel to the permanent hub, and the following hints will be useful:—

WOOD OR PRESSED STEEL WHEELS.—These types offer little difficulty as the gear ring can be attached direct to the inside hub plate, which is a part of the hub; for this purpose we supply a gear ring with instanding lugs to reach well over the plate. For this particular front drive we require to know the size of front wheel tyres, running radius of front tyres as per Fig. 20 on page 28, diameter of flange, number and size of bolts in flange and centres of same, and length of flexible shafting. Fitting instructions for above would be precisely the same as for an ordinary gear drive.

WIRE WHEELS.—These wheels generally have a permanent part of the hub exposed in the saucer of the detachable wheel, and we can supply a special carrier, known as the "Spider" fitting, which serves to support the gear ring, and the latter always remains on the permanent hub. For this type of front wheel, we require to know make of detachable wheel, running radius of front tyre as per Fig. 20 on page 28, diameter of that part of the hub exposed in the saucer of the wheel, and length of flexible shafting. Fitting instructions for this drive are generally as for an ordinary gear drive, but care must be taken to make the spider fitting a tight fit on the permanent hub.

Special spur gear rings can be supplied for the 1913 Crossley Car, in which the spider fitting is embodied in the gear wheel, and the fitting is extremely easy.

THE SMITH MOTOR CYCLE SPEEDOMETER DRIVES AND FLEXIBLE SHAFTING (Front Wheel Drive)

The front wheel drive for the Smith Motor Cycle Speedometer is an exceedingly compact and efficient fitment. The spur gears are cut by a

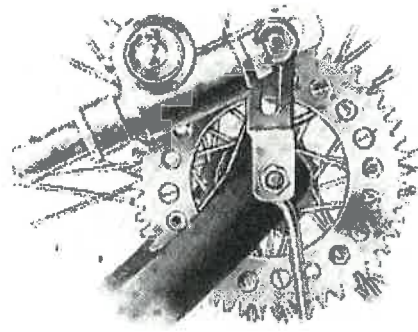

Figure 16. — Type No. AA201.
The Smith Motor Cycle Front Wheel Drive.

special method, in which the teeth are generated so that the working is smooth and practically noiseless. The internal spiral gears are hardened and ground to ensure their lasting properties.

The exterior of the gear housing is nickel-plated and well finished, and the drive when fitted is quite

DETACHABLE WHEELS

Detachable wheels very often cause a good deal of trouble in fitting speedometers. It is obvious that if the gear wheel is attached to the spokes of the wheel, either wood or wire, the speedometer would be out of action if the wheel is removed to change. It is therefore advisable to fit the spur gear wheel to the permanent hub, and the following hints will be useful:—

WOOD OR PRESSED STEEL WHEELS.—These types offer little difficulty as the gear ring can be attached direct to the inside hub plate, which is a part of the hub; for this purpose we supply a gear ring with instanding lugs to reach well over the plate. For this particular front drive we require to know the size of front wheel tyres, running radius of front tyres as per Fig. 20 on page 28, diameter of flange, number and size of bolts in flange and centres of same, and length of flexible shafting. Fitting instructions for above would be precisely the same as for an ordinary gear drive.

WIRE WHEELS.—These wheels generally have a permanent part of the hub exposed in the saucer of the detachable wheel, and we can supply a special carrier, known as the "Spider" fitting, which serves to support the gear ring, and the latter always remains on the permanent hub. For this type of front wheel, we require to know make of detachable wheel, running radius of front tyre as per Fig. 20 on page 28, diameter of that part of the hub exposed in the saucer of the wheel, and length of flexible shafting. Fitting instructions for this drive are generally as for an ordinary gear drive, but care must be taken to make the spider fitting a tight fit on the permanent hub.

Special spur gear rings can be supplied for the 1913 Crossley Car, in which the spider fitting is embodied in the gear wheel, and the fitting is extremely easy.

THE SMITH MOTOR CYCLE SPEEDOMETER DRIVES AND FLEXIBLE SHAFTING (Front Wheel Drive)

The front wheel drive for the Smith Motor Cycle Speedometer is an exceedingly compact and efficient fitment. The spur gears are cut by a

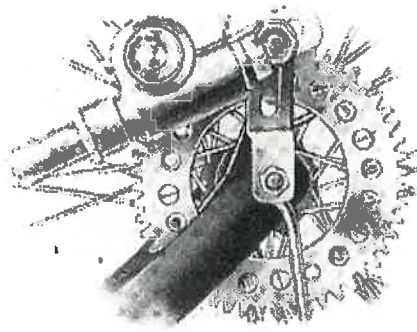

Figure 16.—Type No. AA201.
The Smith Motor Cycle Front Wheel Drive.

special method, in which the teeth are generated so that the working is smooth and practically noiseless. The internal spiral gears are hardened and ground to ensure their lasting properties.

The exterior of the gear housing is nickel-plated and well finished, and the drive when fitted is quite

unobtrusive, and does not detract from the pleasing lines of the front wheel forks. This drive is made for all sizes of wheels, and with brackets for all type of front forks such as A. J. S., Chater-Lea, P & M, where the standard bracket (as illustrated) cannot be applied. Special fittings are also made for motor cycles with interchangeable wheels, so that the gear is in action whenever wheel is fitted.

MOTOR CYCLE BACK WHEEL DRIVE

This form of drive is eminently suitable for most of the American motor cycles. The illustration shows the Drive fitted on a Harley Davidson machine, but it can be supplied for Indian, Excelsior, etc. It may also be applied to the heavier types of English machines, on which it has proved

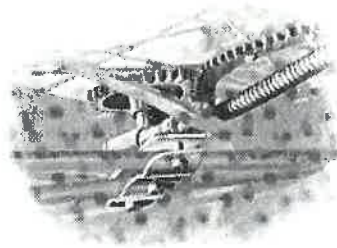

Figure 17.—Type No. AA203.
The Smith Motor Cycle Back Wheel Drive.

particularly successful. The same general details as to manufacture, finish, etc., as given above for the Front Wheel Drive, apply to the Smith Back Wheel Drive.

FITTING INSTRUCTIONS FOR MOTOR CYCLE FRONT WHEEL DRIVE

This Drive is so easy to apply that we do not think it necessary to give very much detail with regard to same, but would simply point out that the small spur wheel should not be placed too near the line of the wheel spokes, and that great care should be taken to well tighten the nuts and bolts of the fitting.

The drive spur wheel is attached to the spokes of the cycle wheel by a simple arrangement of plate washers, nuts and screws; the gear box is fitted in the most convenient place to miss mud-guard stays, etc., and need not necessarily be in the position shown in the illustration above.

MOTOR CYCLE GEAR-DRIVE LUBRICATION.—The motor-cycle gear box should be lubricated by removing the cap which is directly opposite the 17 T. spur wheel.

To remove this cap it is necessary to take out the small split-pin at the side and then simply screw off the cap.

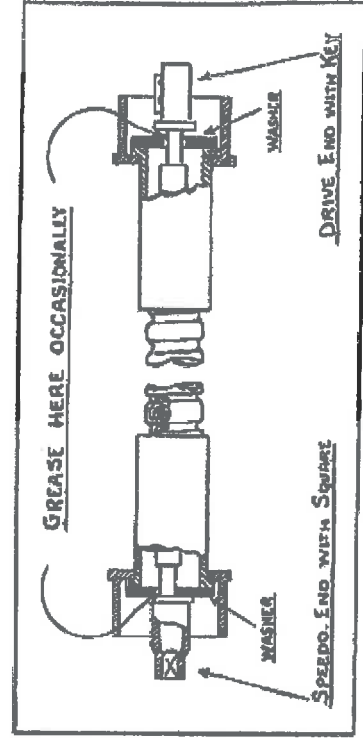

Figure 18.

The cavity should then be filled with a good thin grease, such as Prices' "Belmoline," and the cap screwed on and then re-locked with the split-pin; the screwing on the cap will act as a ram and force the grease to all parts of the box.

See below re Flexible Shafting Lubrication and Attachment Instructions.

ATTACHING FLEXIBLE SHAFTING

In fitting either of the Drives described above, care should be taken to arrange for the flexible shafting to have as few bends as possible; the straighter and more direct the drive the longer the life of the shafting will be.

In no case should the flexible shafting be fitted to give a bend of more than half a complete turn, and radius of same should not be less than 9" or 10".

When attaching the flexible shafting to either the Drive or Instrument end, the key ends of the shafting should be moved about until they drop into their slots. On the Drive and Speedometer the key end should drop in quite easily, and when they are in place a supporting washer should rest on the screwed bases of the Instrument and Drive (see Fig. 18).

The flexible casing union can then easily be screwed home. Force should not be used, as the parts are designed to fit quite freely and accurately.

LUBRICATION.—Before finally attaching the flexible shafting to the Speedometer and Drive, a small portion of grease, such as Prices' "Belmoline," should be pushed into the opening in the Speedometer and Drive where the flexible shafting

keys enter. This quantity need not be more than enough to cover one's finger tip. The flexible shafting should be lubricated about every 3,000 to 4,000 miles by taking out the inner flexible shafting, cleaning it down and applying thin grease, such as Prices' "Belmoline," in small pieces or blobs all the way along so that there is a fair supply of grease in the tube.

Should occasion arise to re-solder inner shafting into nipple, care must be taken that the strands are soldered solid before affixing into nipple. "Fluxite" is the best soldering medium.

DUPLIX SPEED INDICATORS

Any two types of instruments can be applied. The bracket holding the solid pulley should be attached to the chassis exactly in the same manner as for an ordinary cardan shaft fitting with a single speedometer; a special fitting known as the "Duplex Shaft End Fitting" must then be attached to the spindle of the cardan drive in place of the nut which secures the solid pulley to same. In this case the Duplex Shaft End Fitting serves as a securing nut to the solid pulley, and should be pinned to the spindle through the hole in the Duplex Cardan Shaft Fitting.

The Speedometer inside the car is generally fitted in the centre panel between and below the folding seats—if any—and the most suitable types of instruments for this particular arrangement are:—Type AA 21—British Type, Type AA 31—De Luxe Type.

For Gear Drive to Duplex Instruments it is simply necessary to fit an ordinary front wheel

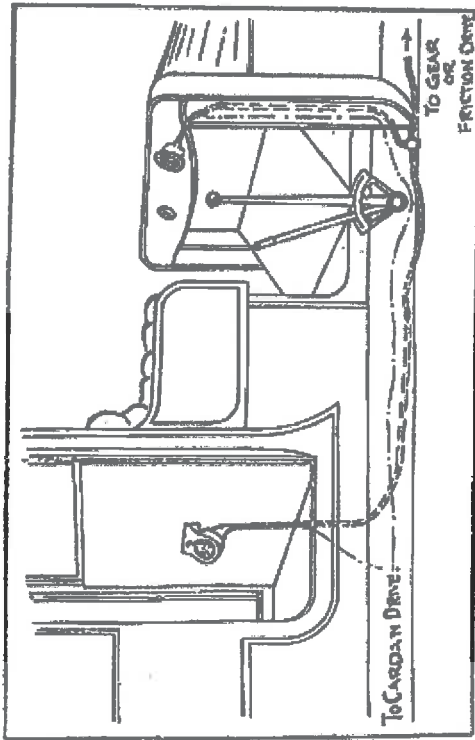

Figure 19.

drive and adopt the special three-way piece as shown in the above diagram.

FODEN, YORKSHIRE, OR SIMILAR COMMERCIAL DRIVES

We make a distinct feature of supplying special drives for the above, and many other steam and petrol Commercial Wagons.

The Drive is particularly efficient, and it is driven from a wheel on the engine, which is in constant ratio with the back wheels, and owing to its favourable position in the engine casing, it does not get the hard usage peculiar to other forms of drives.

For this type of Drive we require to know the number of teeth on the two chain wheels, running radius of back tyres (Fig. 20) and number of teeth on engine wheel nearest the edge of the chassis, as well as pitch of same.

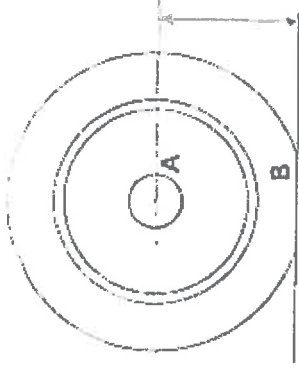

Figure 20.

In giving sizes of the Tyres as requested above, please measure the distance from the ground to the centre of the hub as shown on diagram herewith at A.B.

These dimensions should be taken when the Tyres are in condition of running, and with the approximate usual load on the Car.

As well as these dimensions, kindly give the size of Tyres as stamped thereon.



APPROXIMATE REVOLUTIONS OF WHEEL PER MILE

After having made Allowance for Compression

PLAIN STUDDÉ

Tyre Size	Approximate Running Radius		Revolutions		Gear Ring	Approximate Running Radius		Revolutions		Gear Ring
	Per Mile	Per Kilometre	Per Mile	Per Kilometre		Per Mile	Per Kilometre			
650	12½"	830	515	815	67	12½"	505	69		
700	13½"	770	480	750	72	13½"	465	74		
710	13½"	755	470	740	73	13½"	460	75		
750	14"	720	446	700	77	14½"	435	79		
760	14½"	700	435	690	78	14½"	430	80		
800	15"	670	415	660	83	15½"	410	85		
810	15½"	660	410	650	83	15½"	405	85		
815 or 820	15½"	655	405	645	84	15½"	400	86		
840	15½"	640	396	630	87	16"	393	89		
850	16"	630	393	620	88	16½"	388	91		
870	16½"	620	385	610	89	16½"	376	92		
875	16½"	615	382	605	91	16½"	375	94		
880	16½"	610	380	600	91	16½"	370	94		
895	16½"	600	372	590	92	17"	365	95		
910	17"	590	366	585	94	17½"	360	97		
915 or 920	17½"	585	362	575	95	17½"	358	98		
935	17½"	575	355	565	95	17½"	350	99		
1010	18½"	535	335	520	104	19½"	325	107		
1020	19½"	525	325	510	105	19½"	315	108		

A NEW ERA IN MOTORING

Motor Experts are unanimously agreed that the motoring industry has now entered on a new era, and practically every Motor Car Manufacturer is now busily engaged in completing plans to deal with the huge volume of business which is expected almost immediately.

New principles and new ideals will be predominant in all types of cars, and it is generally agreed that most of the cars of the future will be "Ready-for-the-road," which means that Manufacturers will supply their cars fully equipped in all respects, without requiring the addition of further accessories and fittings.

In pre-war days the usual practice was for a man to buy his car, and then fit all the accessories at additional heavy cost; in after-the-war days the purchaser of a car will know beforehand the exact expenditure he will incur.

The advantage of this plan is that Manufacturers will be able to standardise not only the chassis and the body, but also the accessories and the fittings of the car, thereby effectively reducing the cost of the completed car to the buying public.

It is obvious, therefore, that the production of a high quality car, complete in every respect for the road, at a moderate and reasonable all-inclusive cost, will tend to make motoring much more popular in the days to come than it was before the War.

Established in the year 1899, Messrs. S. Smith & Sons (M.A.), Ltd., have rapidly achieved fame

as the foremost Motor Accessories House, and for many years their specialities, by sheer merit alone, have been the preferred accessories of motorists in every country in the world.

With this reputation to maintain, and having in mind the post-war standardisation programme of the motor-car manufacturers, Messrs. S. Smith & Sons (M.A.), Ltd., have given very great attention to the improvement of their specialities.

Before the War, 13 out of 14 British car manufacturers standardising instruments fitted the Smith Equipment, and it is worthy of note that upwards of 30 of the leading post-war cars will be similarly fitted and equipped.

During the War we have been solely engaged on the production of instruments of precision for aeroplanes, and, in fact, Messrs. S. Smith & Sons (M.A.), Ltd., have produced more Aviation Instruments for the British and Allied Governments than any other firm. The experience thereby gained has been of vital importance, enabling us to perfect our vast organisation for the production of post-war motor accessories.

Every article has undergone a complete change in design; its quality has been consistently improved; the finish and durability perfected; its operation made absolutely reliable; and prolonged, expensive, and independent tests have proved them worthy the paramount place as post-war accessories.

The Smith Equipment will also be available for the man who already owns a car which is not yet fitted with accessories, and the prices have been fixed as low as possible consistent with high quality materials and skilled workmanship.