

HOW A MAGNETO WORKS

John Nutting's expedient for a recalcitrant magneto is to retire to the pub with his mate Tony. An eminently sensible way to start this series — which, after this explanation, will include a practical stripdown and rebuild of the tatty item which has caused him so much trouble in the past.

MY old mate Tony could always turn a catastrophe into a moment of mirth. "If lighting is in the control of the Prince of Darkness, then magnetos are subject to equally sinister demons," he smirked.

I had to laugh. My duff BTH magneto was getting to me, I had to admit, and after a frustrating couple of hours I was on the verge of defeat. Tony had lightened the occasion. Over a pint of bitter, we tried to analyse the situation.

That BTH was a thing of beauty for me. Passed across from various British twins I had owned in the sixties and seventies, it had the solid feel of a .357 Magnum pistol in the hand, yet with light-alloy castings and covers it looked a treat. Even the tiny contact breaker set was machined from a solid piece of alloy.

And could it pack a spark! Just spinning the shaft in the hand could produce a jolt that would waken the dead. But now, outside the pub, the bike was just lifeless.

"I'm blown if I know what it could be", I groaned as the last dregs of the bitter flowed. "It's fine when the engine's cold, but as soon as I've gone a few miles down the road it starts to stutter and then die. And it's definitely not the fuel."

Tony scratched his stubble. "So it's when the magneto's hot that it's not producing a spark."

"Not entirely. there's a very weak spark, but not enough to fire the mixture."

"Hmmm. Sounds just like the pro-

blems when a condenser goes in coil ignition. Let's have a look at the points."

Out we went to the Triumph. In seconds, the end cover of the mag was off and I was spinning over the twin with the plugs out.

"There you go. Look at that." Tony's glee was impossible to conceal. "The points are sparking all over the place. The condenser's duff and the sparks run through the points instead." Minutes later, the magneto had cooled enough to return to its former glory and I chugged home.

Trouble was, how to mend the mag? You don't change a condenser just like that. It needed more skilled attention.

Such was my initiation to the eccen-

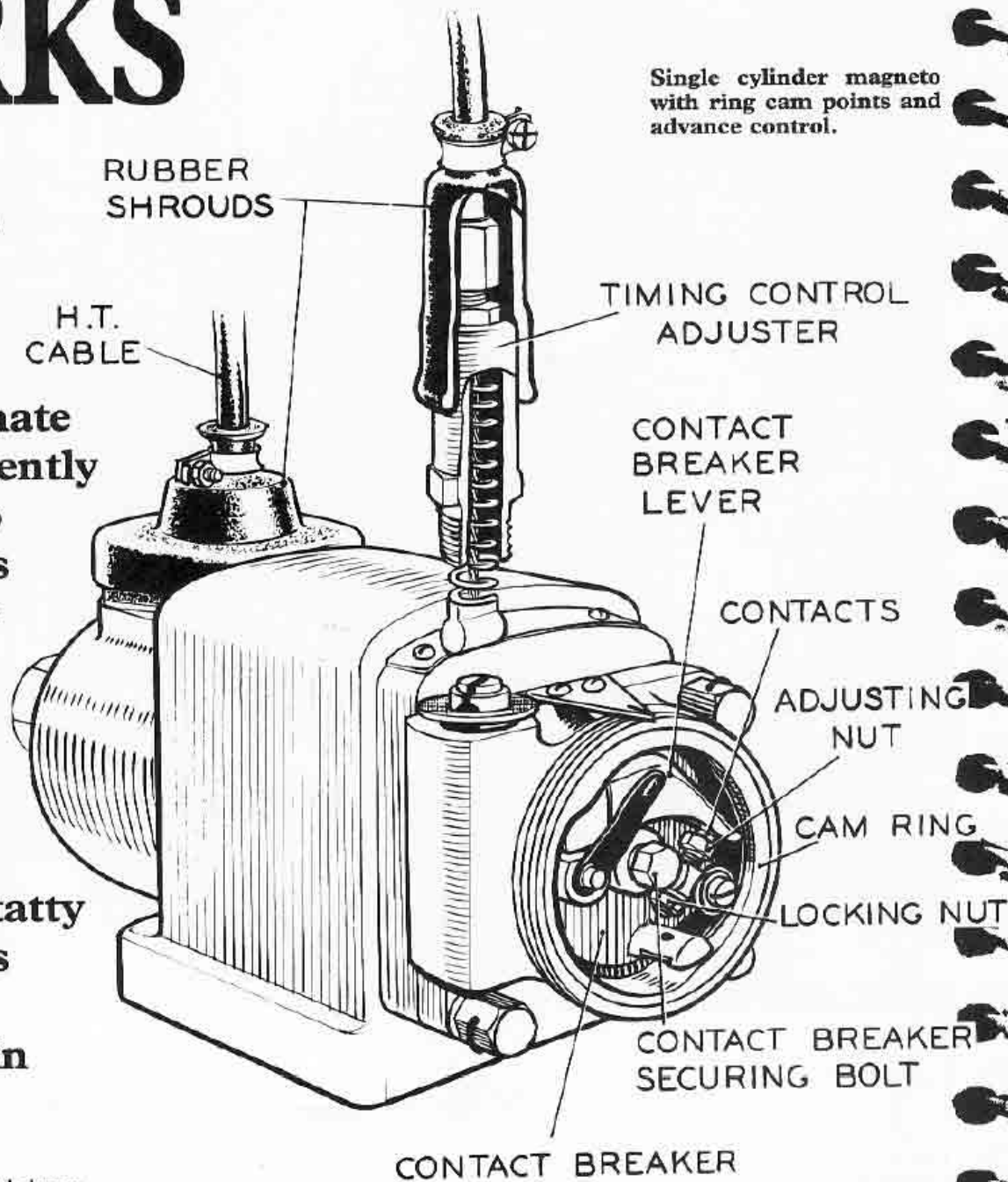

Single cylinder magneto with ring cam points and advance control.

RUBBER SHROUDS

H.T. CABLE

TIMING CONTROL ADJUSTER

CONTACT BREAKER LEVER

CONTACTS

ADJUSTING NUT

CAM RING

LOCKING NUT

CONTACT BREAKER SECURING BOLT

CONTACT BREAKER



tricties of magneto mysteries.

THEY do indeed seem to be prey to sinister forces, but only because they are, most of the time, self-contained devices for supplying ignition.

And so they were when they first became universally adopted by motorcycle and car manufacturers in the twenties. All that was required on the car or bike engine was a drive of some sort, by gear or chain, and somewhere to sit the magneto.

Eventually various types were devised to suit different configurations of engines, whether singles, vee-twins or parallel twins. They were the convention, right up to the sixties and early seventies, when the last manufacturer to use them was Velocette.

With the advent of higher output alternators and more reliable electrical systems, the ignition duties were taken over by coil ignition systems which, with fewer mechanical components, were

cheaper to produce than the magneto.

Nowadays, magnetos for motorcycles use are serviced only by specialists and their cost runs into hundreds of pounds for a unit.

But as a source for the production of high-energy ignition they are just as good (if not better in many cases) as modern ignitions. Their only drawback is the need to service the points and the lack of proper ignition advance system which in these days of computer controlled systems is provided by mapped record of the engine's requirements.

The problems of my own BTH magneto prompted me to delve

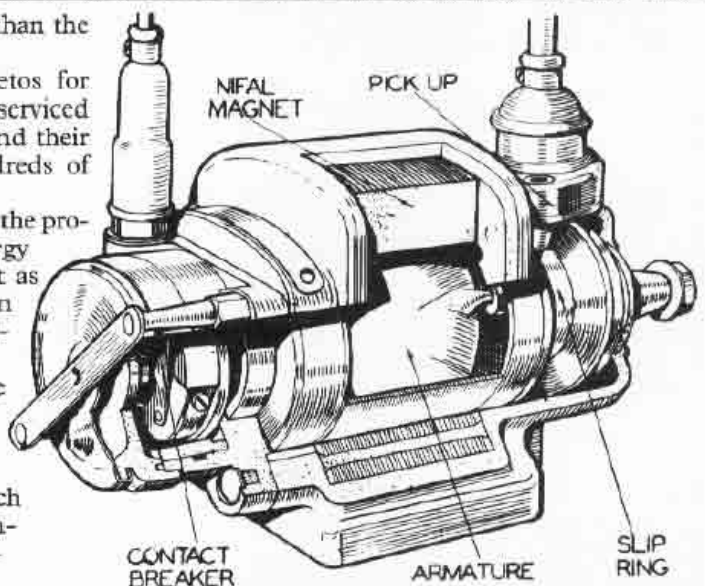

The modern Lucas magneto for single-cylinder machine has a Nifal magnet. This, unlike the older cobalt type mentioned in text, does not have to be protected with a "keeper" to avoid loss of magnetism during overhaul.

The grotty magneto removed from an equally grotty AJS (left) that is to be stripped and rebuilt in this series. The bike may also be the subject of a later restoration series.

"So when you stop the current, by earthing it with a set of points, the magnetic field collapses. When that happens another field is formed by what is called the back EMF, or electro motive force. And that creates another voltage. The faster the field collapses, the higher the voltage.

"Now, if you make up a coil with a higher number of turns, like a transformer, surrounding it to capture that field you can get thousands of volts out of the system."

Tony was getting his steam up by now. Another pint helped. "On any ignition system, you've got to stop that voltage sparking back across the points. You want all the energy to go into the high tension side and the spark plug.

"So a condenser is placed across the points. It acts like a buffer to absorb the voltage. But because it's made of sheets of aluminium and paper closely packed, it's prone

to failure of the insulation. That's what happened to your magneto."

I had a look at the illustration in the book. It showed the condenser inside the rotating armature. "Doesn't that mean the armature's got to come apart?" I moaned.

"Well yes," said Tony. "But for an expert it won't take long. Don't worry. I was just getting to the good bit.

"The brilliant thing about a magneto is that it makes its own power. It's just like an alternating current generator. As the rotating coil in the armature cuts through the magnetic field of the magnets in the body, it creates an AC current that uses the low tension coil as a load. If there is no ignition this would simply leak to ground.

more into the complexities of the device. But I could find nothing of real help in my electrical engineering text books from college. I phoned Tony. "It'll take too long on the blower. How about a pint," he suggested.

At the pub, Tony had brought along a couple of old motorcycle magazines. "Look at these," he said. I was still confused.

"Look at it like this. Ignition's the same which ever way you look at it. You can't destroy energy. When you've got a current flowing in a coil it generates a magnetic field. That's a potent force. You can't just stop it there and then. The energy has to go somewhere.

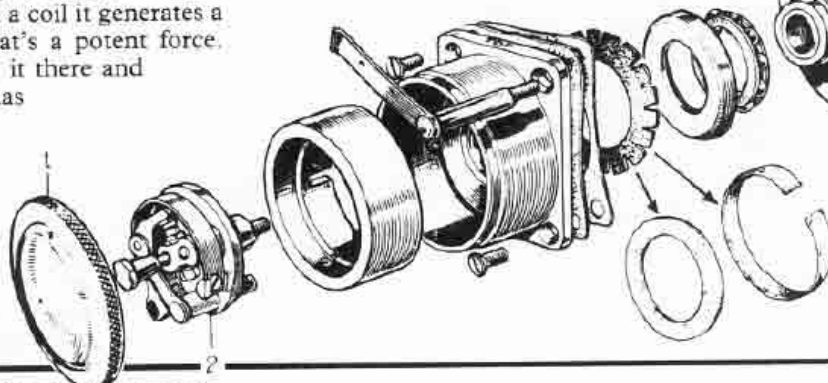
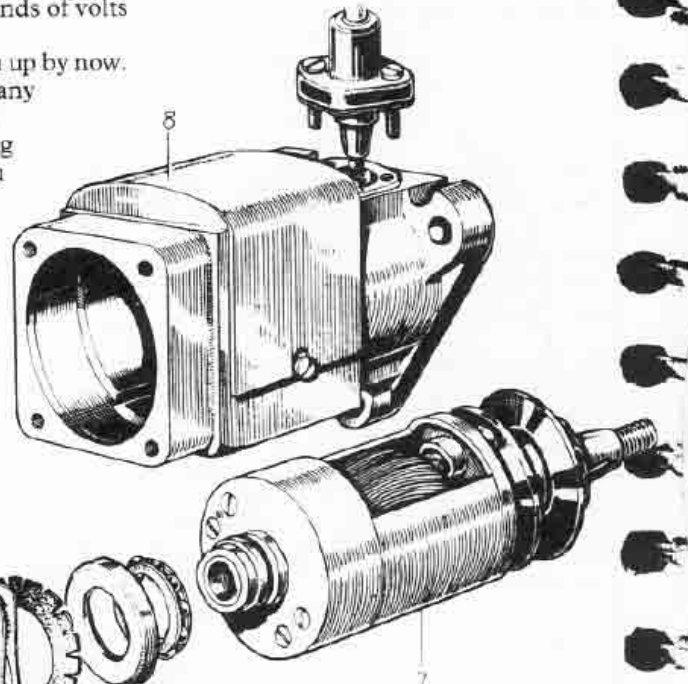

This dismantling sequence should be memorized when working on a B.T.H. magneto. Special extractors may be necessary for bearing withdrawal.

"Another way of looking at it is shown in Roy Bacon's book here on electrics. He says that the shape of the pole pieces supporting the rotting coil concentrates the flux of the magnets, which is when you're supposed to close the points."

"That's when the current is at its peak, and when the strongest spark will be produced."

Fine, I thought. "But if the armature's rotating, how can the spark be transmitted to the plug?"

"That's simple," said Tony. "Through a slip ring near the drive end of the mag body. A carbon brush rubs on the slip ring to pick up the voltage."

"Hang on a minute." My mind was spinning. Whether it was the Theakstons bitter or the pace of the information I don't know, but there were more than a few mysteries still to be unfolded.

"If the armature's spinning in bearings, why doesn't the current go to earth that way? And how does the contact breaker connect the coils to earth if it's rotating on the shaft?"

Tony winked. "I see you're getting the hang of this. The armature has to be electrically self-contained, but also run in bicycle type ball bearings. These bearings have outer races which are supported in insulating paper cups."

"Often the earthing connection is tricky to find. Mostly you'll find it underneath the contact breaker plate, or sometimes under the maker's plate. The magneto won't work without it."

"There are one or two other things you should know," continued Tony. "If you plan to take the magneto to pieces make sure you first remove the high tension safety screw. This is at the drive end

SEGMENTS FOLD
ROUND RACE
WHEN FITTED

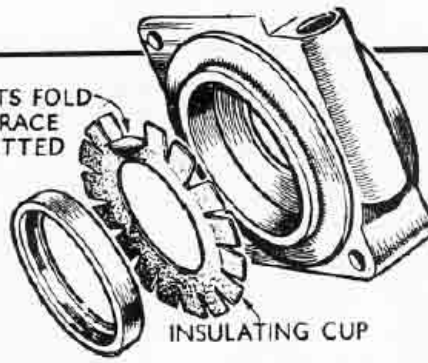

INSULATING CUP

The K2F Lucas magneto is fitted to a large number of vertical twin-cylinder engines. In working on this instrument important items to note are the insulating paper cup and bearing assembly, shown top left, and the use of shims to give armature end clearance.

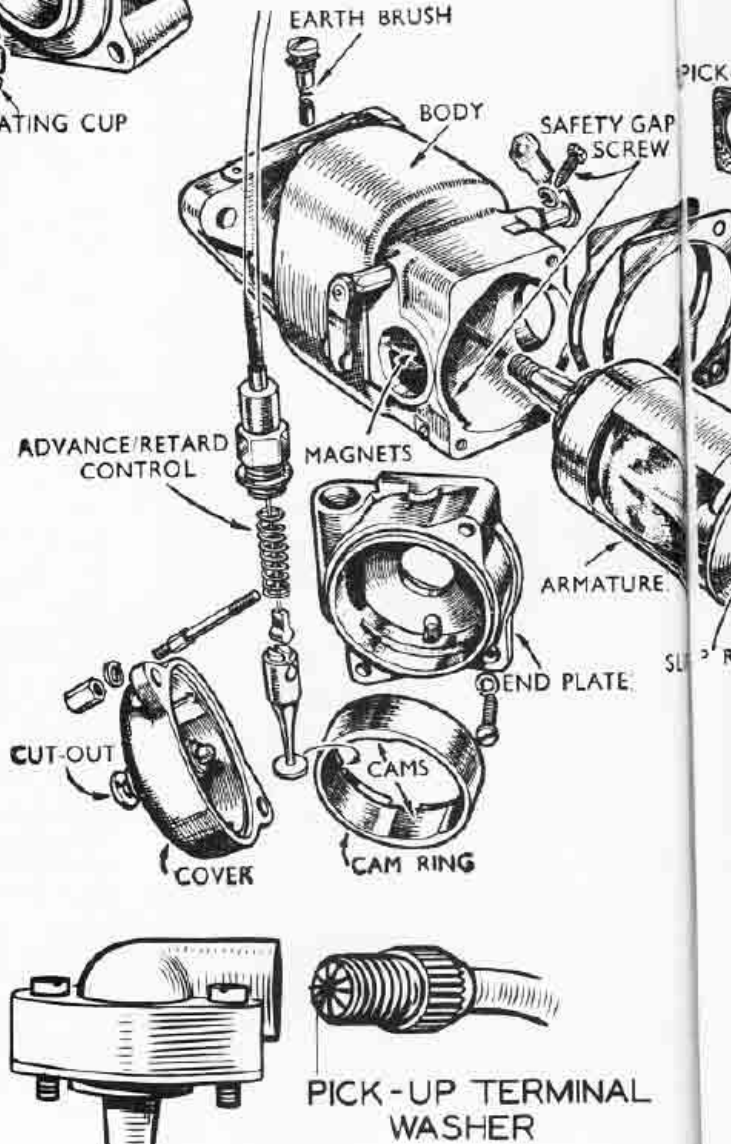

CONTACT BREAKER COVER

CONTACTS

LOCK NUT

SPRING CONTACT

CONTACT BREAKER SECURING SCREW

CAM BACKING SPRING.

CARBON BRUSH

Single cylinder magneto with face-cam points.

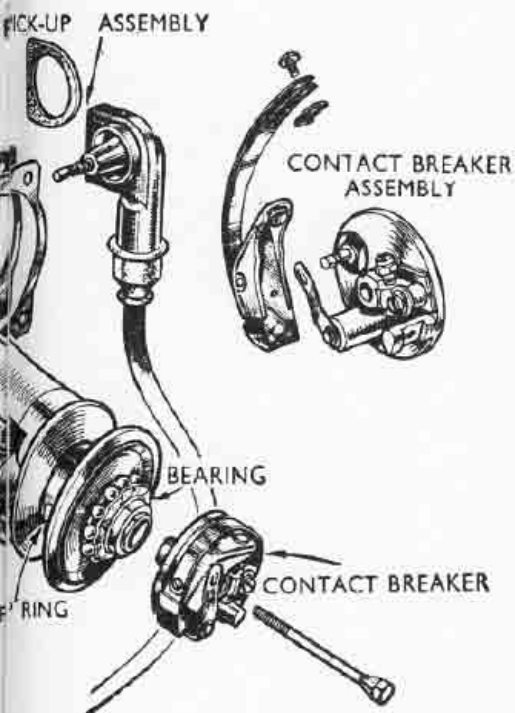

Right: Nick Peyton of Geoff Dodkin Motorcycles holds a newly refurbished K2F Lucas magneto. Loads a money!

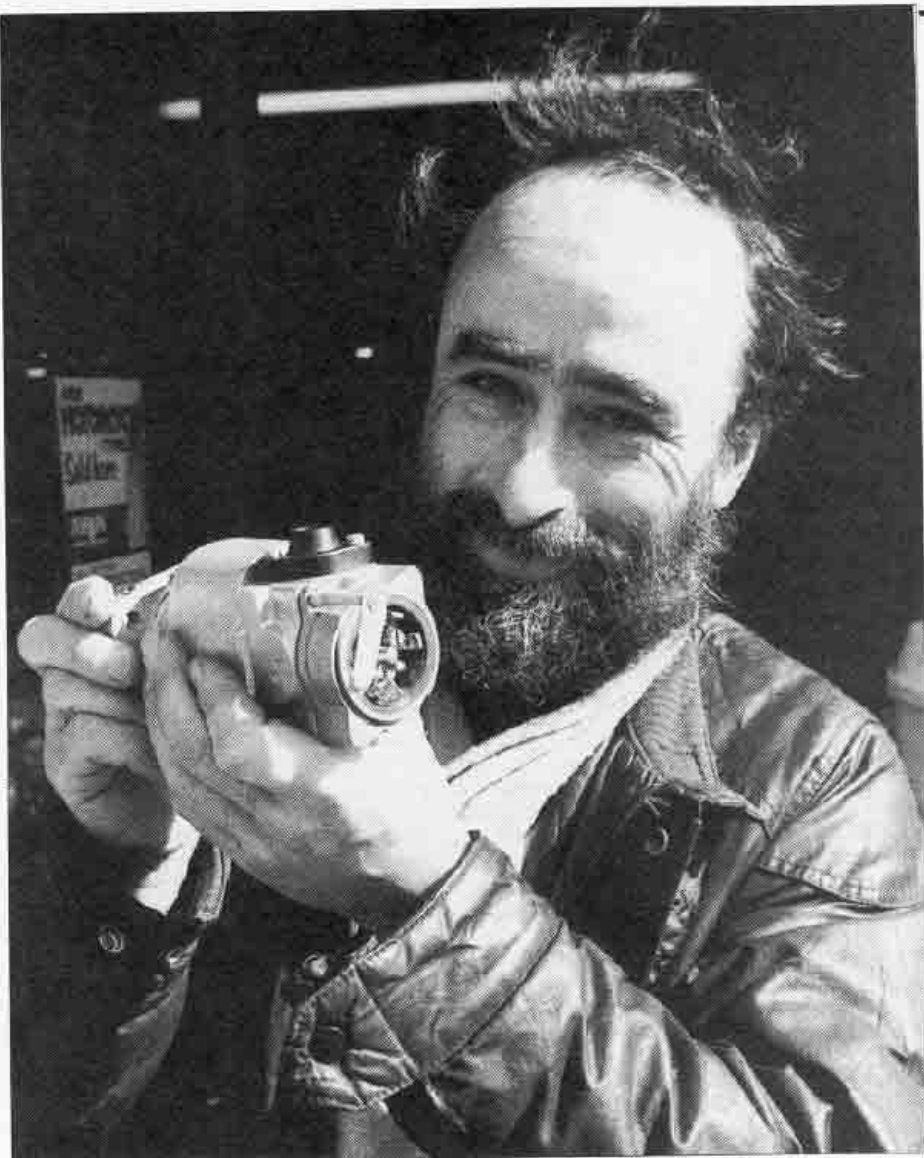

and points down into the gap between the edges of the HT slip ring."

I couldn't conceal my furtive look. "Don't tell me," said Tony, "you've already done it."

"Yes. And yes, I broke the edge of the slip ring off. But it'll be okay with some Araldite. Learn by experience I suppose."

WE had 'just one more' while I found out how the contact-breakers work — that there can also be face cams as well as internal twin lobe cams for opening and closing the points on my BTH.

This example had two cams for the twin high tension leads which screw into the body. Others, as in the Lucas series, have clip mounts for the HT leads, as well as more secure and water-proof screwed types.

The first magnetos were mostly mounted on flat supports and secured with a strap. The drive would invariably be by chain, which could be adjusted by moving the magneto or packing it on its support plate. Sprockets were fitted to a taper on the drive shaft, so timing of the magneto by moving this could be substantially varied.

To provide a measure of advance and retard, the internal cam for the points could be made to rotate by means of an

external cable controlled from a handlebar lever. This, however, meant that the spark could never be as strong as when it was timed from the peak current point of the armature.

Other automatic advance systems have been developed, including centrifugal arrangements built into the drive sprocket on later British twins. These were in-

types of magneto are apparently small but can have a significant effect on performance. Magnetos were made for variety of vee-angles for example, with at least six different vee-angles. None will work with another.

SO, to understand magnetos some knowledge of the various designations is a help.

The landlord's bell rang. "Stone me, it's closing time already," said Tony. "Doesn't time fly when you're having fun. Want another?"

"No thanks. It's my round though. I'll buy."

"Great. We must do this some more. Tell you what, I'll bring some more books the next time and we'll talk about how magnetos go wrong and how to mend 'em, okay?"

I plonked the pint on the table. "You're on," I grinned, knowing that the Triumph would be back in action by the weekend. And I wouldn't have to worry about the demons.

'I broke the edge of the slip ring off... it'll be okay with some Araldite.'

variably those magnetos which also had the later three-bolt flange fitting, but the two could also be mixed.

The most sophisticated development of the magneto was with its rotating magnet version. Rather than have an armature rotating inside a pair of magnets, in this type (designated SRR1 by makers Lucas), the magnets were on the rotating armature and coils arranged adjacent so that brushes or slip rings were unnecessary.

Nevertheless, a contact breaker set was still required, the twin cylinder version providing sparks through a distributor.

The differences between the various

**● Next Issue:
diagnosing problems
and rectifying them.
On Sale August 15th.**

WHAT CAN GO WRONG?

Well, it's a Summer's day, the birds are singing, but the Thunderbird has died a death. Tracking down the fault is the problem. John Nutting's lyrical tapestry of magneto mystery stories enters another phase.

"OH, damn it!" I groaned. Somehow, to feign indifference to the crisis I plucked at a blade of grass and started chewing it. Behind us, the Dominator and the Thunderbird pinged as they cooled down by the side of the road. We sat on a grass bank and looked out through the heat haze across a low valley. Grasshoppers chirruped. The girlfriends were exploring further down the bank. A lovely spot, in time and in space.

Tony broke the silence. "It might be something quite simple, let me have a look", he offered. Tony was eternally confident. Despite the circumstances, a grey cloud hovered over my head. I'd had problems with the Triumph's old BTH magneto and been startled at the

Tony. "Got the plug spanner?" I rummaged through the bulging pocket of my Belstaff and displayed the tool. "Whip out the plugs and let's see what we've got." Tony held one of the plugs against the head as he kicked the Triumph's engine over. What we had was nothing. No sparks at all.

"I suppose that you set the contact breaker gap correctly, and timed the ignition?" Of course, I answered, trying to grasp the line of thought.

"The points gap might have closed up," said Tony, "so there'd be no spark." But after taking off the end cover, the points were opening and closing to order, though it was tricky to see as they rotated on the end of the mag's spindle.

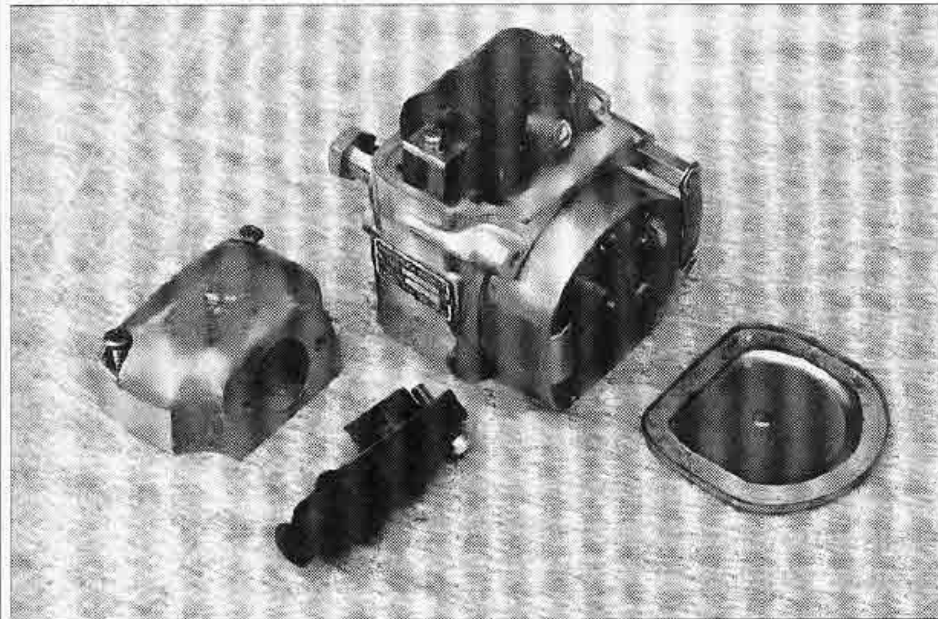

The Mitsubishi single-cylinder magneto with the various covers removed — for the points (right) and the high-tension coil (left).

cost of repairing it, so I had grabbed the chance of a Lucas K2F mag I'd been offered cheap.

Now here we were, and the bike had stopped again, after stuttering for several miles.

"Come on, let's have look," said

Tony then took off the high tension terminals after slipping off the clips. "Don't know why I'm doing this because there's no spark on either side," he admitted. "Still we might find something."

Both of the sprung-loaded carbon brushes were dry and clean, their springs intact. They were put back into their



housings. Tony brightened. "Let's try the earth brush, that might be causing the trouble if it's fallen out." I'd not even thought of that, or much else for that matter. It had been enough trouble bolting the thing on and getting it timed up.

The earth brush was under a brass screw on the top of the drive end of the mag. Like the high tension terminals, it looked perfectly okay. "I dunno," said Tony. "Put the plugs back in and let's see what happens." By now the girls were back and looking impatient, kicking pebbles about in the layby.

I kicked over the bike. It fired up. Tony looked puzzled. I beamed at the girls in triumph. "Right, let's go," I cheered. "Don't forget that end cover", said Tony.

I reached for the kill button to cut the engine. The bike wouldn't stop. And then it dawned on me, just as it dawned on Tony. We both pointed to the button. Unscrewing the button, the internals fell out. They'd been clearly shorting out the mag. The cover was refitted, less



"The girlfriends were exploring further down the bank"

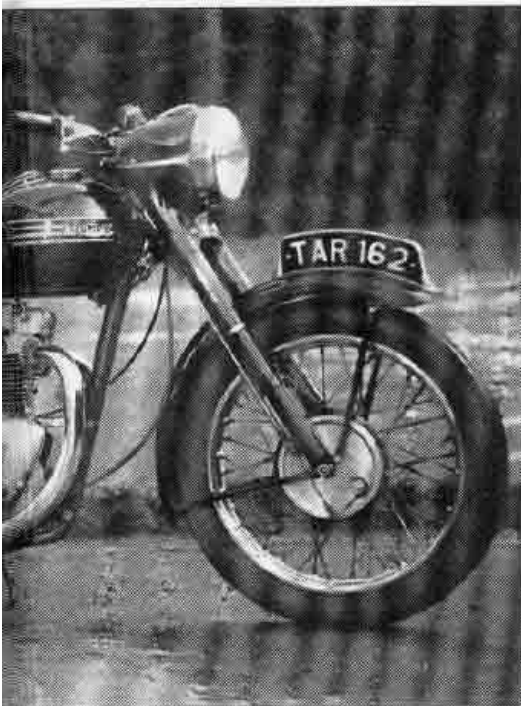

As the Triumph pinged as it cooled, Tony, ever confident, said the problem could be something simple. The earth wire, and we set off.

LATER, back in the converted lock-up we shared, Tony explained that my magneto problems might have been much worse. "Most people seem to think that they're 'fit-and-forget' items. That once you've bolted them on they go forever.

"But they don't, as you found out. And there's maintenance you can carry out to keep them in good trim.

"First, the points (whether operated by a internal circular cam or a face cam) should be kept clean and the full open gap correctly adjusted. Like any points system the contacts should have smooth faces and meet each other flat on. Make sure all the various screws are tight and that they have the appropriate insulating washers fitted.

"Naturally, the foot of the contact arm where it rubs on the cam should be lightly lubricated with a dab of high-melting point lithium grease.

"The points assembly mounts on the taper and is keyed into the armature shaft. This taper should be burr free and

clean so that the points plate is true when bolted up. The key ensures that the points open at the maximum flux being generated by the armature.

"Wear occurs on the high tension pick-up rings. The main part of the ring is a plastic moulding with the brass HT contacts within them. The plastic can wear, leaving the brass proud of the surface and this can wear out the carbon brushes prematurely.

"The brass faces can be polished down but if the step is too large then careful lathe work will be required. The same goes for the earth brush we had a look at by the side of the road." As far as regular maintenance of the magneto on the bike is concerned, that's as far as you can go. Signs that all is not well can include the appearance of oil in the magneto, which indicates that the oil seal

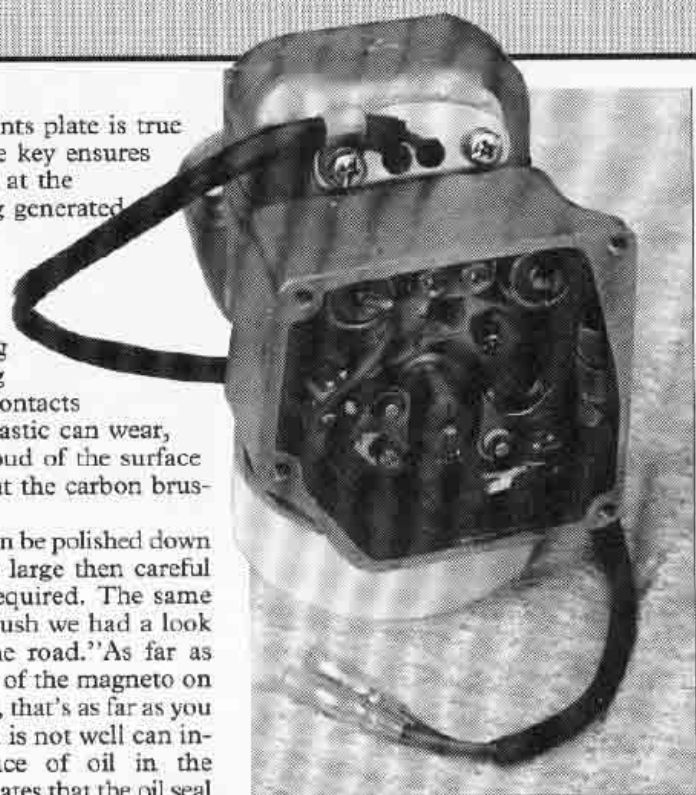

The twin cylinder Mitsubishi magneto showing the separately adjustable contact breakers and easily accessible condensers.



Remote high-tension magneto with rotating magnets, fitted to the Manx Norton.

on the drive side has failed, and general deterioration in the quality of the spark.

"A well maintained magneto should be able to produce a spark that will jump a gap of at least a quarter of an inch. Assuming of course that the spark plugs and caps are in good nick.

"The magneto armature has two bearings which are of the angular contact type similar to a bicycle wheel's. They must be set to the correct clearance, and this is usually achieved by varying the number of thin paper shims under the points casting until there is zero clearance. The bearings should be lubricated with a high melting point grease.

"A point I should have mentioned is

that whenever you take off the magneto and disassemble it, you must not leave the armature out of the casing. The magnets can lose as much as a quarter of their power if the armature is removed, which can only be restored with special magnetising equipment.

"When all else fails to restore a magneto's performance, it's usually because of a failure in the wiring inside the armature, which mean the magneto must be sent off to a specialist for refurbishment.

"As we found with your BTH magneto, the condenser can fail. This was usually a mica assembly inside one end of the armature, and encapsulated. Nowadays these are replaced with more



modern 'potted' units with a much higher rating.

"The shellac insulation on the low and high tension windings of the armature is more likely to be the culprit in a failed magneto however. And although the windings might seem tough enough on the outside, they may be soft on the inside, where most of the heat is generated.

"The only cure for this is to have the armature rewound with polyurethane insulated copper wire and vacuum sealed.

"Finally, the magneto might have simply lost its magnetism, in which case, it requires setting up on a magnetiser. This is a big device with large coils which give the magneto's magnets a huge jolt of magnetism, and the job's done."

I frowned at the BTH magneto on the bench. "There's got to be a better way than having all this wiring whirring around inside the magneto," I asked.

"And so there has been," Tony replied. "Lucas made rotating magnet magnetos for racing, but they were very expensive and are now very difficult to get hold of. Bosch also made a rotating magnet device with an external high-tension coil for the same purpose.

"In fact, magnetos are still being made in Japan and Czechoslovakia.

"A subsidiary of Mitsubishi makes mags for singles and twins and they're both — as you'd expect — as modern as you could find. Both are made for the peculiar oval track racing they have in Japan which still use Triumph twins and similar homemade machines.

"The mags have rotating magnets with conventional fixed points operating from a normal cam on the shaft. The condenser is easily accessible. But while the tiny single cylinder mag is self contained with co-axial low and high tension coils, the twin cylinder magneto uses external high-tension oils.

"So these mags are very easily maintained. Better still, because they use the same platform (single) or three-bolt flange fittings, they are direct replacements for the old British magnetos.

"The Czechoslovakian magneto is made by PAL and is made for speedway engines like the Jawa. This, too, is a rotating magnet design and has an external HT coil.

"So if you're really keen to keep your magneto rather than replace your ignition with a battery and coil arrangement, it's still possible to obtain new and reliable units for your machine."

Tony looked smug with himself. He might have told me **The PAL magneto uses a platform mount and an external high-tension coil.**

Far right: This magneto from Mitsubishi uses external HT coils and a standard three-bolt flange fitting.

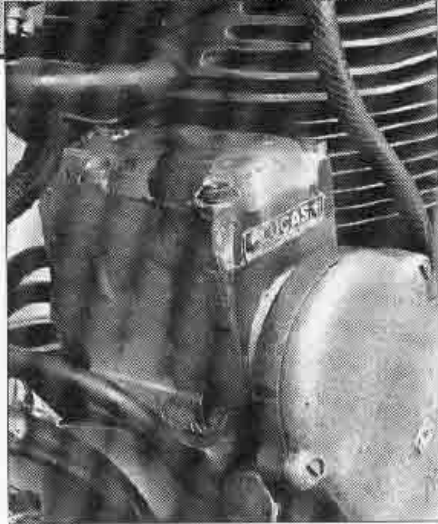
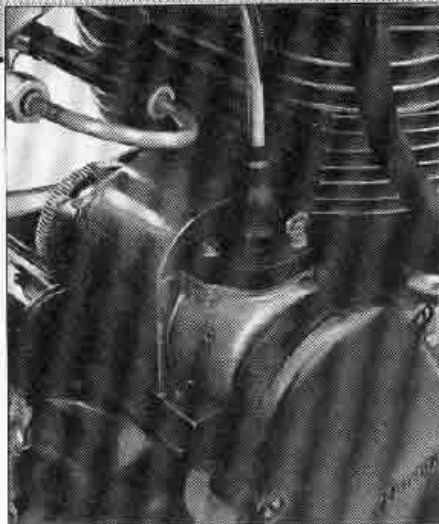

These early Lucas rotating magnet items are becoming increasingly difficult to obtain with prices for refurbished units reaching £1000. That's why more modern new magnetos are selling well for between £150 and £250.

everything there was to know — or at least what he knew — about magneto problems. But my BTH was still silent.

Then the phone rang. It was Dave, who was rebuilding his old A10 as a semi-chop. "Hi mate. You know you

said I could replace the magneto with a coil ignition and points. Well, now I don't have to. I've been given a lovely Lucas K2F for it. Everything's loose on it. Do you know anything about it?"

"No," I said, "but I know a man who does."

New magnetos from Japan and Czecho

OLD magnetos can be refurbished but they are becoming increasingly difficult to obtain and expensive.

Fortunately, new modern magnetos are being manufactured in Japan by the Koshida Shoko Corporation, a subsidiary of Mitsubishi, and imported into the UK by TGA Classic Motorcycle Services. Two types of magneto are offered, one for singles and one for twins. Both have rotating magnet armatures and accessible coils and condensers for easy maintenance.

The tiny single cylinder mag is self contained and although platform mounted requires a 6mm packing plate to make it the same height as a Lucas-style magneto. Only problem when fitting to a Manx for example is that the unit's so small a new type of clamping strap is needed.

The drive shaft taper and left-hand thread is identical to the old magnetos. Price is £210 plus VAT

and comes complete with spare points and a condenser.

The twin cylinder magneto has a three-bolt flange fitting so can be a direct replacement for the K2F type of unit. It has two sets of individually adjustable points and external condensers. It also has external high-tension coils. Price is £350 plus VAT including a pair of spare points sets and condensers.

Supplies of the Czechoslovakian PAL magneto may be drying up soon, so get one while you can. Again this is for single cylinder engines and has a platform mount. It's a rotating magnet unit with a small external HT coil. Price is a very reasonable £155 plus VAT.

TGA Classic Motorcycle Services is run by Graham Boothby from Smithy Cottage, Liverpool Road, Bickerstaffe, Lanes L39 OEF. Tel 0695 423621.

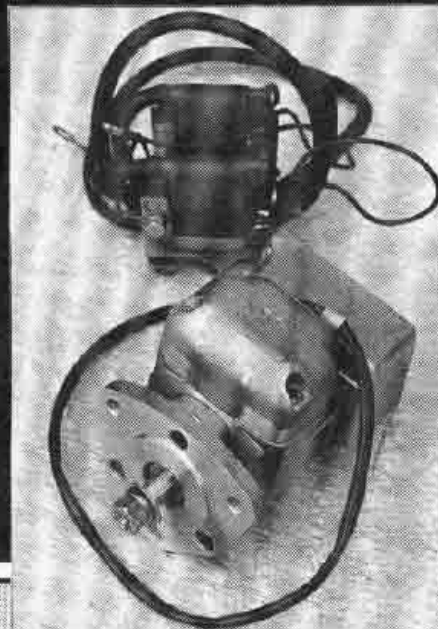
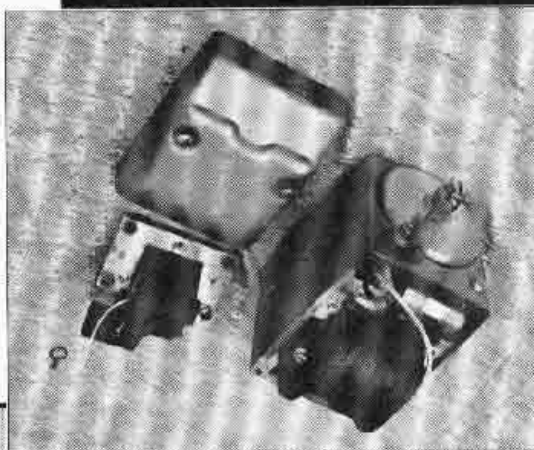

STRIPPING THE MAG

Even though a magneto looks like a simple device, it's not. When John Nutting wanted two stripped down for inspection, he took them to expert Elwin Jenkins, whose been servicing magnetos for over 30 years.

WELL? Whaddya think of it?" Dave passed the magneto across the table. He was beaming with delight. "I never thought I'd be able to get hold of one like that. It'll go great on the Beesa."

I had to admit that the Lucas device that I was holding looked, at first glance, to be okay. It was clean, but perhaps too clean, and certainly nothing like the encrusted lump of antiquity I'd pulled off the 350cc AJS.

Now that was something I'd never seen before, the Ajay's mag that is. Hazy recollections told me the bike was hidden at a friend's farm, but it still took two laps before I found the rancid tarpaulin and the rusting remains of the big single beneath. Anticipating a struggle to remove its magneto, I found it came off with a single spanner and a crosshead screwdriver. The years had left their mark, the whole unit encased in dust and grime with the points exposed to the weather. It looked like a hopeless case.

By comparison, Dave's Lucas twin magneto was spotlessly clean. But closer examination showed that all was not well. The points assembly fell out as I opened up the end cover, and the points spring twanged in its moment of freedom. But as I spun the armature the magnets felt strong and there was only the slightest amount of end float in the shaft.

"I can't be sure about this, Dave," I

Elwin Jenkins with the dynamic magneto tester at his workshops. A 1.5 hp electric motor runs up the magneto as various checks are made on the serviceability of its various components.



admitted, "I'll have to take it along to a magneto expert I know. I'll see what he thinks."

Elwin Jenkins is one of a small band of specialists who service the growing need for looking after the electrical requirements of classic motorcycles. A keen bike fan and restorer, he is rare in that he's been providing a service for more than 30 years, having started before the decline of the British industry when magnetos were still specified for many models.

Of course, he's seen lean times, especially during the period after the collapse of the industry and before the resurgence of the classic revival.

Over those years he's made more than a few useful contacts, and appears to take a pride in the fact that he can still extract batches of new magneto armatures and other important bits from the Lucas factory, although they have long been out of production.

In addition to being able to obtain new parts, Elwin has a number of useful suppliers for services like coil rewinding and cam grinding, not to mention all the tiny but crucial screws and shims. Finally he has commissioned the manufacture of items like points sets, end covers and high-tension terminals, many of which are unobtainable elsewhere.

He is critical of many magneto

specialists who he thinks carry out too much work on mags — and charge accordingly — when a straightforward check would suffice, and thinks that the charges often made for rewinding are over the top.

Elwin gave me a knowing look when I showed him the two magnetos at his Slough home. He immediately identified the unit from the AJS as an N1 Lucas. "It feels okay," he said, spinning the shaft. "But this K2F is a bit of a bitsa, he said. "I'll have to look at it more closely."

So, appearances were at complete odds with the facts. The rough-looking N1 was in better condition than the tarted-up K2F.

And this was confirmed when I return-

Body and end cover of the Lucas K2F magneto. Markings suggest that it had been serviced by Pride and Clarke, but the body had been welded and the end face needed remachining.

Armature of the K2F magneto with the HT slip ring removed showing the connecting wire that was failing to make correct contact with the ring.

ed a couple of weeks later. Both magnetos had been stripped and the components laid bare. Magnetos are easy, perhaps too easy, to dismantle, as I've found in the past to my cost. And there are important things to remember when doing so.

Most times, all the servicing that will be necessary for the owner to carry out is the timing of the spark, which may entail checking the points — dressing the contacts and checking the gap is correct — and ensuring that the firing point is correct by removing and refitting the drive sprocket with the engine and magneto positioned at the right point.

When wear starts to take place, say in the bearings, on the heel of the points, in the ring cam on a unit with timing variable by a cable, or on the high-tension slip ring, then it is all too easy to take off the magneto and pull it to pieces.

It takes the removal of just two, or three at the most, screws to take off the end cover and extract the armature. But you should be aware that in doing so the magnets in the body will promptly lose up to a quarter of their power. And there's nothing you can do about it but to send the lot to a specialist for remagnetising.

So unless you really know what you're doing it's best to leave well alone. Even

2



3

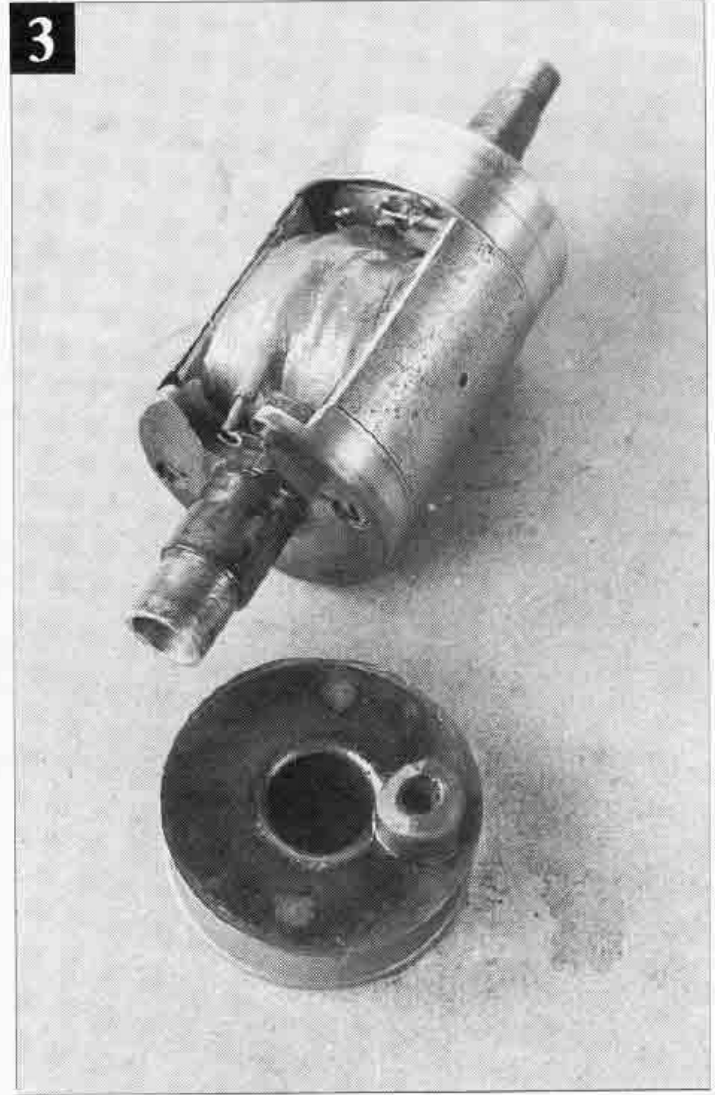

though a magneto appears to be a simple mechanical device, the subtleties of its electrical design are not immediately obvious.

In particular, items like the earthing brush, which is often hidden from view under the identification plate. And the high-tension earthing pin which protects the HT coils, which must be removed before the armature is taken out or it will break the material on the side of the HT slip ring.

With a wealth of experience, and parts to hand, specialists like Elwin Jenkins can cope with almost anything they face. Occasionally, some magnetos can present a challenge, such as the one that had been unused for 30 years and had an armature rusted into the casing. A couple of weeks soaking in Plus-Gas was just the start of a process toward the complete rebuild of the mag, but it's working again.

ELWIN saw the K2F as an interesting but not uncommon story. "The chamfer on the (bottom front of) body shows it to be for a BSA twin from 1953 to 1963. Markings on it suggest it was supplied or serviced through Pride and Clarke (a big Stockwell dealer that closed in the early seventies) so it is probably from about 1957.

"It's had a heavy life and it's mix and match of bits. The body has been rewelded at some point and someone's been at it with a file. It's not a tidy job."

Elwin then turned to the K2F's points assembly. None of it looked right. "Apart from the retaining screw for the spring, the small pip on the top of the points pivot is missing, and the small key on the taper mount has broken off, so it would be impossible to time the points correctly. "That's no problem though because I can form another key 180-degrees opposite. It makes no difference."

Elwin didn't have much good to say about the armature either. "Although it's been cleaned up, the rough surface indicates that the armature has been rusty at some time. I checked the windings with a meter and found that there was an intermittent fault. At some time or another, it's been rewound but the connection into the slip ring wasn't made correctly and the spark had a job to jump across the gap before getting to the slip ring. It's formed a carbon bridge but that's broken now."

Was there any good news? "The bearings feel alright," said Elwin, "but only thin shims have been used on the shaft. The end face of the body should really be faced off true, and the armature reshimmed.

"It's got odd HT connections, and the points cover earth connection won't work because the connection's broken," Elwin added. "I've still to check the armature on the tester."

This is where rebuilding of magnetos

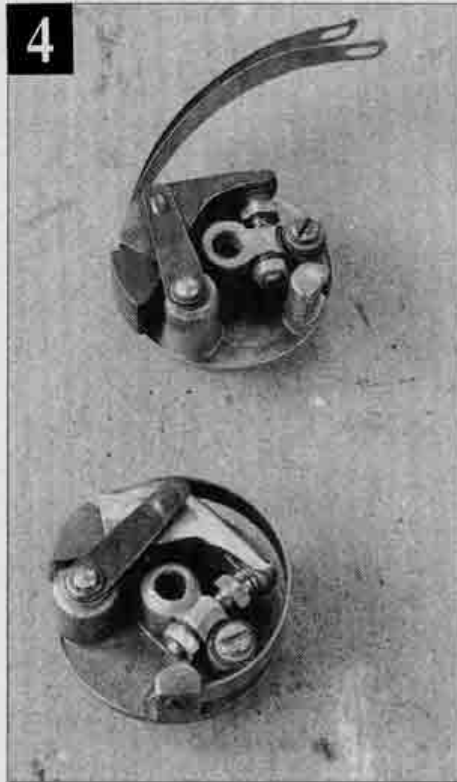

turns into an almost dark science. Most of us have trouble understanding the basics of electrics such as volts, amps and ohms. But when magnetism, coils and condensers get involved in the process then it's a totally different ball game.

Not only does a coil carrying a current generate a magnetic field, which will resist any changes in the current, but voltage and current go out of phase with each other when the current is rising or falling.

Attempt to break the current (as when the points open) and the magnetic field will collapse, generating a 'back electromotive force' or reverse voltage which is multiplied by the thousands of fine tur-

The old points set (top) looked as if they'd been thrown together. A new set are shown for comparison.

A completely rebuilt K2F magneto (this time for a Triumph twin) with new fittings, terminals and end cover.

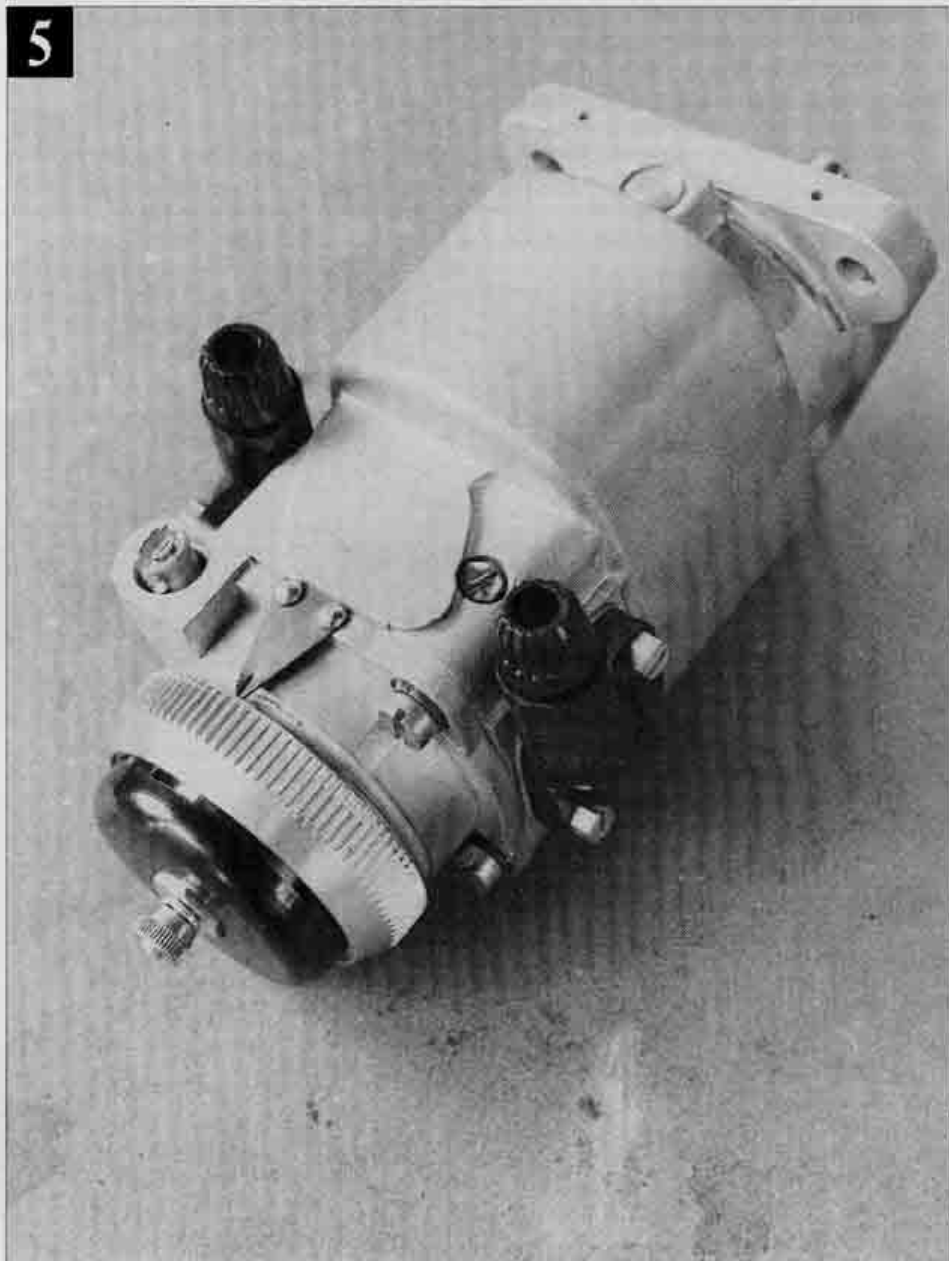

6

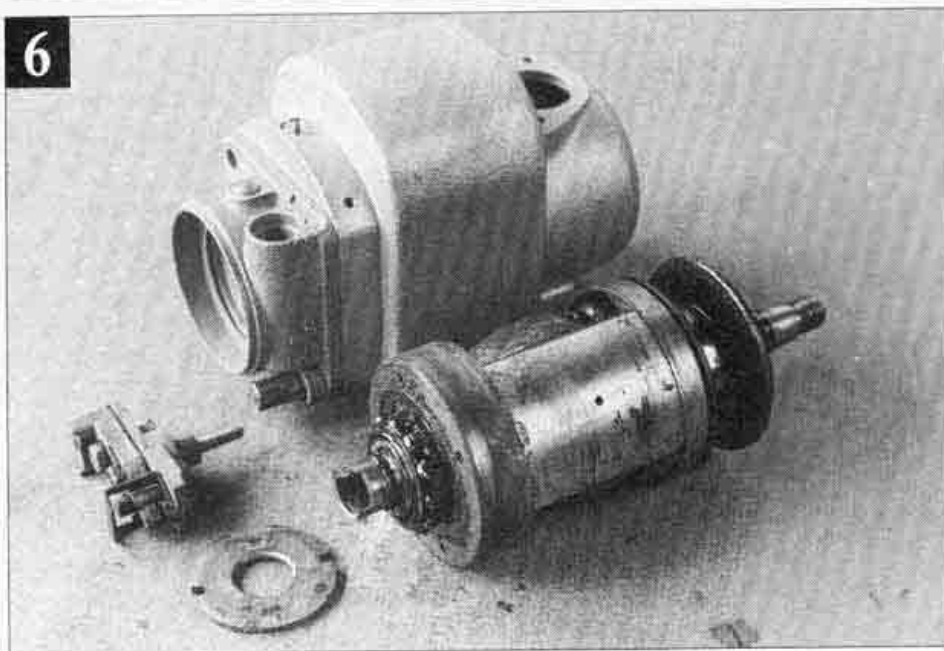

The Lucas N1 Magneto dismantled with the body cleaned up and showing the points assembly, face cam and armature.

Some of the new components that Elwin Jenkins has made for magneto servicing with at the back, the internal points cams for a 50-degree Vincent twin, a parallel twin, a HT terminal and points covers.

nings on the high-tension coil. When this voltage gets high enough, it will spark as required across the plug in the engine's combustion chamber.

To stop the spark jumping across the points instead, a condenser is incorporated into the armature. This acts like a cushion to the rising low-tension voltage as the points open, and protects them from pitting. But it also adds an extra dimension to the difficulty of checking the various components in situ.

Only a dynamic testing rig will provide sufficient information to decide whether the armature should be stripped for the replacement of the windings, and/or the condenser.

Back in the bad old days, the condenser was made of foil and 'potted' into the end of the armature body. Nowadays, Taiwan-made condensers

(two 0.1 microFarad items with 1250 volt rating, if you need to know) are potted into the armature.

There was one final mystery with the K2F. Why had the wrong brass identification plate been screwed into the body? The one used was from an N1 (ironically) dating from early in 1947. We may never know.

BY contrast, the real N1 Lucas mag turned out to be almost faultless under the grime. Made in January 1950, once its body had been cleaned in cellulose and bead blasted, it looked like new. The armature was unblemished and only the bearings showed any signs of requiring attention because on the drive side there was no seal. A new type bearing with a seal

would be fitted.

The face cam was serviceable and although the points had been exposed to the weather for some time, they would work after a dressing. Anyway, as with the K2F, new points are available for much less than a tenner.

With magnetos in only average condition fetching hundreds of pounds these days it's useful to understand what you're buying. You may get away with paying less than £150 for having a mag built, so this must be taken into account if you find that you're being presented with what appears to be a mag in top-class condition. If the seller says the mag's been rebuilt, ask by whom, and ask to see receipts. There are no more than a couple of dozen specialists in the UK and it's worthwhile checking their names before going on a hunt for a mag.

As we found, it's very likely that the rougher the mag looks, the better. If nothing else, it's a sign of being undisturbed.

Anyway, Dave's happy now. "Thanks a lot chief," he said when I returned the K2F. "I didn't realise there was so much to these things," he laughed, "but I can't say I'm all that much the wiser."

7

